

R A D I O N I C S

D7212 Control/Communicator

Operation and Installation Manual

Notice

The material and instructions covered in this manual have been carefully checked for accuracy and are presumed to be reliable. However, Radionics, Inc. assumes no responsibility for inaccuracies and reserves the right to modify and revise this manual without notice.

It is our goal at Radionics to always supply accurate and reliable documentation. If a discrepancy is found in this documentation, please mail a photocopy of the corrected material to:

Radionics, Inc.
c/o Technical Writing
1800 Abbott Street
P.O. Box 80012
Salinas, CA 93912-0012

© 1993 Radionics, Inc., Salinas, CA, U.S.A. All rights reserved.

FCC Notices

Part 15

This equipment has been tested and found to comply with the limits for a Class A digital device, pursuant to part 15 of the FCC rules. These limits are designed to provide reasonable protection against harmful interference when the equipment is operated in a commercial environment.

This equipment generates, uses, and can radiate radio frequency energy and, if not installed and used in accordance with the instruction manual, may cause harmful interference to radio communications.

Operation of this equipment in a residential area is likely to cause harmful interference in which case the user will be required to correct the interference at his own expense.

Part 68

This equipment complies with Part 68 of FCC rules. A label contains, among other information, the FCC registration number and ringer equivalence number (REN). If requested, this information must be provided to the telephone company.

The Radionics D7212 Control/Communicator is registered for connection to the public telephone network using an RJ38X or RJ31X jack.

The ringer equivalence number (REN) is used to determine the number of devices that may be connected to the telephone line. Excessive RENs on the telephone line may result in the devices not ringing in response to an incoming call. In most, but not all areas, the sum of the RENs should not exceed five (5). To be certain of the number of devices that may be connected to the line, as determined by the RENs, contact the telephone company to determine the maximum REN for the calling area.

If the D7212 Control/Communicator causes harm to the telephone network, the telephone company will notify you in advance. If advance notice isn't practical, the telephone company will notify the customer as soon as possible. Also, you will be advised of your right to file a complaint with the FCC if you believe it is necessary.

Part 68 (Continued)

The telephone company may make changes in its facilities, equipment, operations, or procedures that could affect the operation of the equipment. If this happens, the telephone company will provide advance notice in order for you to make the necessary modifications in order to maintain uninterrupted service.

If trouble is experienced with the D7212 Control/Communicator, please contact Radionics Customer Service for repair and/or warranty information. If the trouble is causing harm to the telephone network, the telephone company may request that you remove the equipment from the network until the problem is resolved. User repairs must not be made, and doing so will void the user's warranty.

This equipment cannot be used on public coin service provided by the telephone company. Connection to Party Line service is subject to state tariffs. (Contact your state public utilities commission for information.)

FCC Registration Number: AJ9USA-18808-AL-E

Ringer Equivalence: 0.1A 0.2B

Service Center in U.S.A.: Radionics, Inc.
1800 Abbott Street
P.O. Box 80012
Salinas, CA 93912-0012
(800) 538-5807

Table of Contents

Introduction	7	Power Outputs	22
Areas and Accounts	8	Circuit Protection	22
Communicator	8	Available Power	22
D1255 Alpha III Command Center	8	Continuous Power Outputs	23
Keyswitch	8	Continuous Current Draw	23
Event Memory	9	Programmable Power Outputs	24
Event Log	9	Programming	24
EMI/Lightning Transient Protection	9	Optional Relays Required	24
Programming	9	Terminals 6 and 7	25
Other Features	10	Terminal 8	25
D7212 Control/Communicator Assembly	11	Fire System Power Formula	25
Ordered Separately	11	Telephone Connections	26
Listings and Approvals	12	Registration	26
Fire	12	Notification	26
Burglary	12	Location	26
Installation	13	Phone Cord Connection	27
Before You Begin	13	Phone LED (Red)	27
Enclosure Options	13	Operation Monitor LED (Green)	27
Beginning the Installation	13	Dialing Format	27
Mounting the Enclosure	13	Phone Line Monitor	27
Premises Wiring	14	Phone Line Test Points	28
Installing the D7212 Assembly	14	Communication Failure	28
Connecting Earth Ground	14	Ground Start	28
Locking the Reset Pin	15	Relay Installation	28
Finishing the Installation	16	Ground Start Jumper	29
Charge the Battery as You Finish	16	D128 Dual Phone Line Switcher	29
Install and Wire Detection Devices	16	Operation	29
Install Modules and Relays	16	Primary Phone Lines,	
Make the Telephone Connections	17	Primary Phone Numbers	30
Connect the On-Board Points and Command		Watchdog Feature	30
Centers	17	Installing the D128	30
Power Up	17	D128 Status LEDs	31
Programming the Panel	17	On-Board Points	32
Install the Point Chart Label	17	Description	32
Power Supply	18	Point Sensor Loops	32
Primary Power	18	Point Parameters	33
Primary (AC) Power Circuit	18	Point Response Time	33
Installing the Transformer	18	Off-Board Points	34
Secondary Power	19	Point (ZONEX) Buss	34
Secondary (DC) Power	19	D8125 POPEX Module	
Installing the Battery	19	D8127 POPIT Modules	34
Battery Supervision	19	Installing the D8125 POPEX Module	35
Battery Charging Circuit	20	Wiring the D8125 to the D7212	35
Battery Discharge/Recharge Schedule		Wiring POPITs to the	
(No AC Power)	20	Data Expansion Loop	37
Charging Status and Low Battery LEDs	21	Wiring Data Expansion Loops to	
Charging Status LED (Yellow)	21	POPEX Modules	38
Low Battery LED (Red)	21	POPIT Sensor Loops	38
		Point Assignments	39

D8128A OctoPOPIT Module	41	System Chart	60
Listing	41	System Wiring Diagram, Issue A	61
Installing the OctoPOPIT	41	Current Rating Chart for	
Wiring OctoPOPITs to the D7212	42	Standby Battery Calculations	62
Line Termination	43	Standby Battery Requirements	63
OctoPOPIT Sensor Loops	44	Standby Battery Calculation for	
Off-board Relays	46	Fire Alarm Applications	64
D8129 OctoRelay	46	Troubleshooting Guide	66
Configuring the D8129 OctoRelay	46	Introduction	66
Relay Outputs	46	Self Diagnostics	66
Installation	48	Phone Line Trouble	68
Wiring Connections	48	Communications Failure	69
Arming Devices	49	Problems Programming the Panel	70
Description	49	Problems with Points	71
D1255 Command Centers	49	Problems with the D8125 POPEX	
Assigning the D1255 an Address	49	Data Expansion Loops	74
Installation	50	Checking Shielded Cable	75
D268/D269 Independent Zone Control		EMI on Long Wire Runs	75
D279 Independent Zone Control	51	Problems with Command Centers	76
Keyswitch	52	Battery and Power Reports	77
Description	52	Watchdog Reset Reports	77
Programming	52	Runaway Reports to the Receiver	77
Installation	52	Overloaded Power Supply	78
Keyswitch Operation	52	Command 57 Toggles Default Idle Text	79
Programmer and Accessory Connections	53	Command 59 Toggles Default Idle Text	79
Programmer Connector (J7)	53	Specifications	80
Expansion Port (J4)	54		
Programmer Access Reports	54		
Accessory Connector (J2)	54		
D7212 Faceplate	55		
Quick Reference Terminal Description	56		
Installation Guide for UL and Fire Applications	57		
Listings and Approvals	57		
Fire	57		
Burglary	57		
Optional Compatible Equipment	58		
Burglary Applications	58		
Fire Applications	58		

Figures and Tables

Figure 1: D7212 System Configuration	7
Figure 2: Enclosure Mounting	13
Figure 3: Reset Pin	15
Figure 4: Charging and Battery LEDs	21
Figure 5: Relays for Terminals 7 and 8	24
Figure 6: RJ31X Wiring	26
Figure 7: Telephone Connections	28
Figure 8: Ground Start Relay	28
Figure 9: Ground Start Jumper	29
Figure 10: D128 Dual Phone Line Switcher	31
Figure 11: On-board Point Sensor Loop Wiring	32
Figure 12: D8125 Connections	36
Figure 13: Typical Expansion Loop/POPIT Configuration	38
Figure 14: D7212 Program Record Sheet	39
Figure 15: POPIT Labels	40
Figure 16: D8128A OctoPOPITs	42
Figure 17: D8129 OctoRelay Connections	48
Figure 18: Power at Command Centers	51
Figure 19: Keyswitch Wiring	52
Figure 20: Reset Pin	53
Figure 21: Programmer and Accessory Connections	54
Table 1: Data Expansion Loop Wire Specifications	37
Table 2: D8128A OctoPOPIT Switch Settings	45
Table 3: D8129 Switch Settings	47
Table 4: D1255 Address Settings	49
Table 5: D1255 Connections	50

Introduction

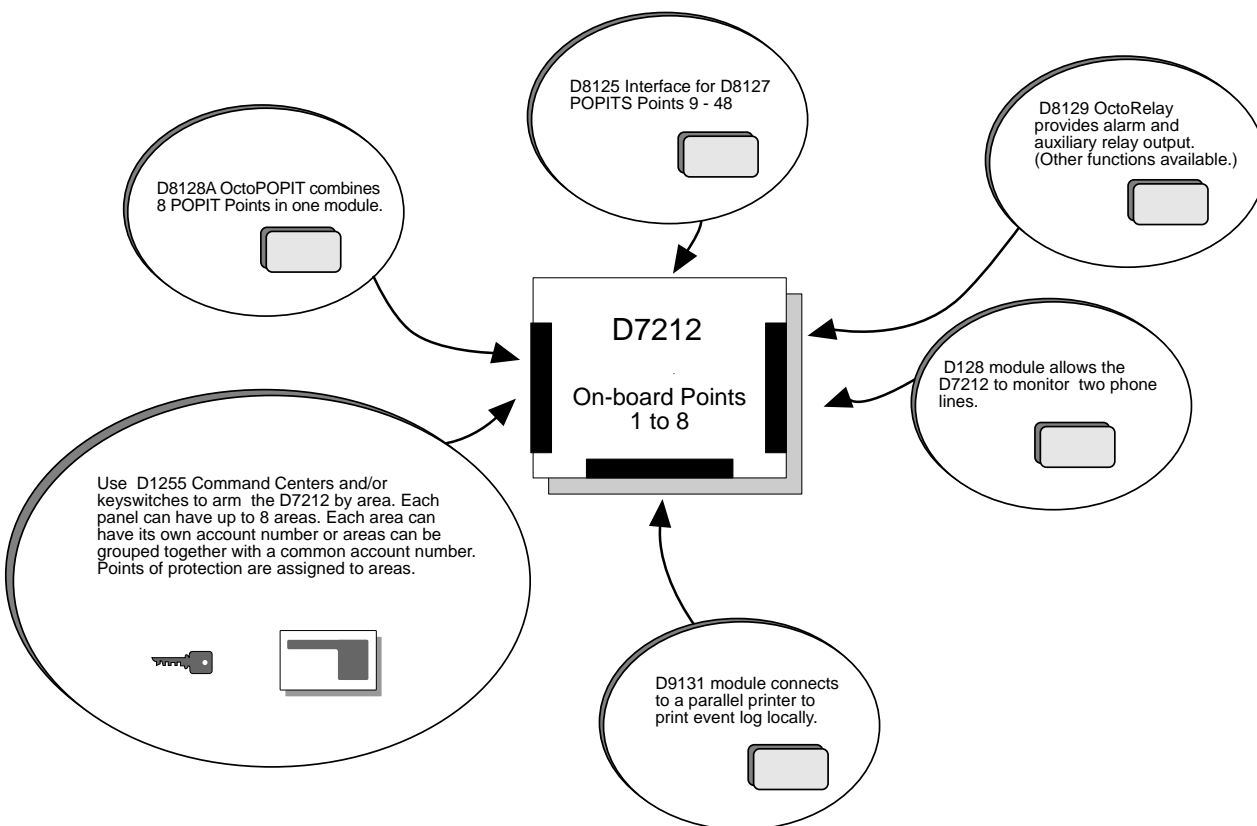

Figure 1: D7212 System Configuration

Points

The Radionics D7212 Control/Communicator panel provides up to 48 separate points of protection. Point programming parameters determine the panel's response to open and shorted conditions on the point's sensor loop. Points are programmed individually with several options to custom-fit the protection to your installation.

Points 1 to 8 are located on the D7212 circuit board (on-board points). They are standard sensor loops. The remaining 40 off-board points are POPIT (**P**oint of **P**rotection **I**nterface **T**ransponder) points. Each off-board point requires a POPIT module. D8127 POPIT modules require the D8125 POPEX module. The D8128A OctoPOPIT module combines eight POPITs in a single module and does not require the D8125 POPEX module.

Areas and Accounts

The D7212 supports up to eight separate areas. You can assign all points to a single area or spread them out over up to eight areas.

You arm and disarm the D7212 panel by area. You can arm and disarm several areas with one menu function. You can also assign a passcode and authority level that allows a user to arm an area from a remote command center in another area. Assigning each area its own account number creates eight separate accounts in one D7212 panel. Assigning the same account number to different areas, groups them together in a single account.

Area options include: exit tone and delay, separate fire and burglary outputs, and multiple opening and closing windows.

Communicator

The Radionics D7212 Control/Communicator panel uses a built-in digital communicator to send reports to the receiver. The panel transmits reports in either the Modem II or BFSK format. Your D6500 receiver's MPU and line cards must have software revision 6.00 (or greater) installed to accept Modem II reports from the D7212. Power your receiver down and up to print the software revision numbers.

The D7212 connects to an RJ31X jack for phone line seizure. Connection to the RJ31X complies with FCC regulations for using the public telephone network. You can program the panel to direct reports to four separate phone numbers. Adding the D128 Dual Phone Line Switcher module allows you to connect and supervise a second phone line.

D1255 Alpha III Command Center

The D1255 Alpha III Command Center offers complete system control and annunciation. The D1255 features an illuminated keypad, a 16-character English language display, and a built-in speaker that offers several distinct warning tones. Switches on the D1255 assign an address (1 to 8) to the command center. You assign addresses to areas in the Command Center Assignments section of the program.

You can connect a maximum of 32 command centers to the D7212. The available power, number of supervised command centers, and number of areas you intend to use, affect the total number of command centers you can connect to the D7212.

The D7212 can supervise up to 8 command centers. The panel transmits a serial device trouble report, `SDI FAILURE` in the Modem II format or `TROUBLE ZN D` in the BFSK format, if it loses communication with a supervised command center. You can add more command centers but only eight can be supervised. See *Command Center* in the *D7212 Program Entry Guide (74-06915-000)* for complete details on command center options.

Keyswitch

You can arm and disarm any of the eight available areas with maintained or momentary closure devices such as keyswitches. Keyswitches connect to points. Point programming determines which area a keyswitch controls. See *Options* in the *Point Index Parameters* module of the *D7212 Program Entry Guide (74-06915-000)*.

Event Memory

The D7212 uses event memory to store events for each area. You can view the events for an area at a D1255 Command Center assigned to the area. The D7212 panel clears the events for an area from event memory and starts storing new events when you master arm the area.

Event Log

The D7212 stores up to 500 events and event modifiers from all areas in its event log. Event modifiers add information about an event to the log. Some events are always followed by a modifier. For example, the D7212 adds at least two items to the log each time you arm or disarm an area, the open (or close) event and an event modifier showing the previous arming state.

All events and their modifiers are stored even if the D7212 does not send a report for them. You can view the log at a D1255 Command Center, print it locally using the D9131 Parallel Printer Interface and a parallel printer, or upload it to a D5300 Remote Account Manager II (RAM II).

See *S- View Log* in the *Security System User's Guide* (71-06141-000) for a complete listing of log events and event modifiers.

EMI/Lightning Transient Protection

The D7212 maintains the Radionics high level of quality and field dependability. Its design significantly reduces electromagnetic interference and malfunction generally caused by lightning.

Programming

Use either the Radionics D5200 Programmer, or the D5300 Remote Account Manager II (RAM II) to program the D7212. Refer to the *D7212 Program Entry Guide* (74-06915-000) for programming options.

Other Features

The D7212 has many programmable features. A short list of some of the features follows. Complete details on all the D7212's features can be found in the *D7212 Program Entry Guide* (74-06915-000).

- Supervision of AC (primary power), battery (secondary power), ZONEX and SDI buses, CPU (Central Processing Unit), 1 printer, and telephone lines
- Automatic system test reports
- Remote access for programming, diagnostics, and log uploads using the Radionics D5300 Remote Account Manager II (RAM II)
- RAM Line Monitor answering machine work-around
- Fire Alarm Verification
- Programmable Alarm Output
- Programmable Relay Output using the D8129 OctoRelay Module
- Opening and Closing Windows
- Skeds (scheduled events)

D7212 Control/Communicator Assembly

The Radionics D7212 Control/Communicator is shipped pre-assembled from the factory. You should receive the following parts with your D7212 panel.

Literature Pack

- *D7212 Installation Reference Guide (74-06913-000)*
- *D7212 Program Record Sheet (74-06894-000)*
- *UL Smoke Detector Compatibility Technogram (73-06143-000)*
- *UL 1023 Household Burglary Technogram (73-06806-000)*
- *Point Chart Label (79-06916-000)*
- Eight 1k Ω end-of-line resistors
- Two 14", 18 AWG, color-coded battery leads
- *Security System Owner's Manual (71-06633-000)*

D7212 Assembly:

- D7212 PC board
- Faceplate shield
- Mounting Skirt
- One #6x1/4" screw

Ordered Separately

Order the following to complete a basic 8 point D7212 installation.

- D1255 or D720 Command Center (or keyswitch)
- D1640 Transformer
- D126 Battery
- D161 or D162 Phone Cord
(order two cords if you are using the D128 Dual Phone Switcher)
- D8103, D8109, or D8108A Enclosure

Listings and Approvals

Fire

UL

Underwriters Laboratories lists the D7212 Control/Communicator as a Signal System Control Unit for:

Central Station, Local, Auxiliary, Remote Station, and Household Fire Warning.

CSFM

Approved by the California State Fire Marshal.

NYC-MEA

Approved by New York City's Materials and Equipment Acceptance System.

Factory Mutual (FM)

Submitted for evaluation by Factory Mutual.

Burglary

UL

Underwriters Laboratories lists the D7212 Control/Communicator for:

Central Station, Local, Police Connect, Mercantile Safe and Vault, and Grade A Household systems.

Department of Defense (DOD)

The D7212 has been granted approval for Department of Defense (DOD) installations in Sensitive Compartmented Information Facilities (SCIF).

Installation

Before You Begin

This *Installation* section contains a general installation procedure. It refers you to other sections of the manual for detailed instructions.

Radionics recommends you review this manual and the *D7212 Program Entry Guide* (74-06915-000) before you begin the installation to determine the hardware and wiring requirements for the features you want to use.

Have the following additional documents handy as you read through this manual:

- *D7212 Program Record Training Sheet* (74-06895-000)
- *Security System Owner's Manual* (71-06633-000)
- *D7212 Operation and Installation Manual* (74-06144-000)

Before you begin the installation of the D7212 you should be familiar with the operation of the D5200 programmer or the RAM II remote programmer.

Enclosure Options

Mount the D7212 Control/Communicator assembly in any of the Radionics enclosures listed below. Refer to the *Installation Guide for UL and Fire Applications* in this manual to determine if your application requires a specific enclosure.

- D8103 Universal Enclosure (gray)
- D8109 Fire Enclosure (red)
- D8108A Attack Resistant Enclosure (gray)

Beginning the Installation

Mounting the Enclosure

Mount the enclosure in the desired location. Be certain to use all five mounting holes. See Figure 2.

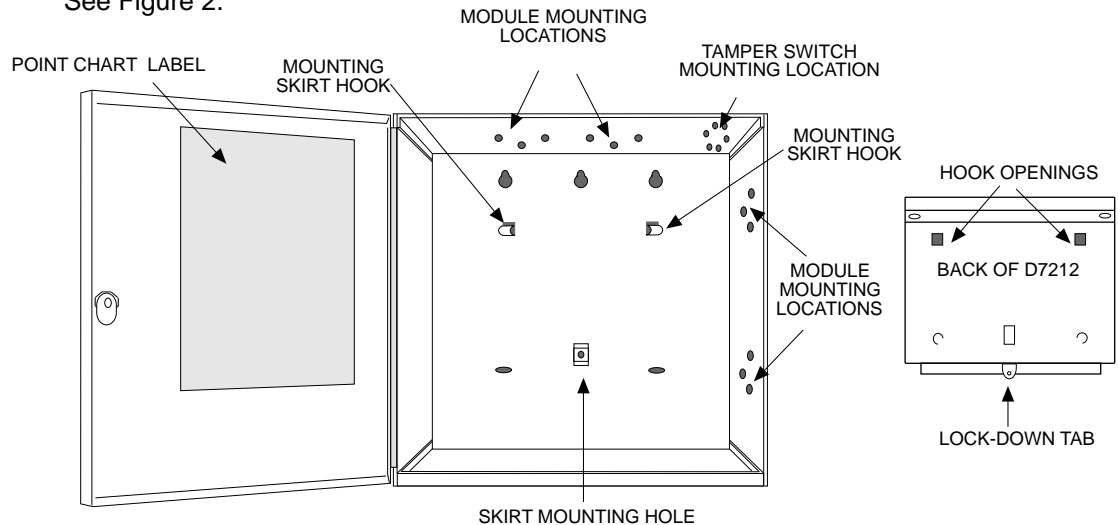

Figure 2: Mounting Enclosure

Premises Wiring

Run the necessary wiring throughout the premises and pull the wires into the enclosure.

EMI (Electro Magnetic Interference) may cause problems: EMI may occur if you install the D7212 system or run system wires near the following:

- Computer network system
- Electrical lines, fluorescent fixtures or telephone cabling
- Ham radio transmitter site
- Heavy machinery and motors
- High voltage electrical equipment or transformers
- PBX telephone system
- Public service (police, fire departments, etc.) using radio communications
- Radio station transmitter site, or other broadcast station equipment
- Welding shop

If you think that EMI may be a problem, use shielded cable. The drain wire for the shielded cable must have continuity from terminal 10 on the D7212 to the end of the wire run. If continuity is not maintained, the shielded cable may aggravate potential noise problems rather than eliminate them.

Connecting the drain wire to ground at other than terminal 10 may also produce problems. If you cut the drain wire to install devices be certain to splice it together. Solder and tape all splices.

Installing the D7212 Assembly

1. Place the D7212 assembly over the inside back of the enclosure, aligning the large rectangular openings of the mounting skirt with the mounting hooks of the enclosure. Slide the D7212 down so it hangs on the hooks. See Figure 2.
2. Remove the tape from the #6x1/4" screw in the mounting tab on the D7212 assembly. The screw passes through the mounting tab and into the skirt mounting hole in the enclosure. Tighten the screw to secure the D7212 assembly in the enclosure.
3. Connect earth ground to the panel before making any other connections. See *Connecting Earth Ground* below.

Connecting Earth Ground

Terminal 10

To help prevent damage from electrostatic charges or other transient electrical surges, connect the D7212 to earth ground at terminal 10 before making any other connections. A grounding rod or cold water pipe are recommended earth ground references.

Do not use telephone or electrical ground for the earth ground connection. Use 16 AWG wire when making the connection. Do not connect any other panel terminals to earth ground.

Locking the Reset Pin

Locking the Reset Pin disables the panel. See Figure 3. The D7212 ignores the command centers and points while disabled. CALL FOR SERVICE appears in command center displays while the pin is locked down.

Existing reports transmitted with Reset Pin locked down: Any reports that are in the panel's report buffer when you lock down the Reset Pin, will be transmitted. However, no new reports can be created with the pin locked down.

To prevent buffered reports from being transmitted, momentarily close the Reset Pin, wait for the buzzer to stop sounding, and then lock the pin down to prevent new reports from being generated.

Locking Reset Speeds Programming: If you have supervised command centers or other supervised devices connected to the Data Bus (terminals 30 and 31), locking the Reset Pin will speed communication between the panel and the D5200.

On-board relays (terminals 6, 7, and 8) and off-board relays, deactivate when the panel is reset. There is power at terminal 8 when the relay is deactivated. Activation interrupts power at that terminal. The relays remain deactivated while the Reset Pin is locked in the disable position.

You can program the panel while it is locked in the disable position with either the D5200 or D5300 (RAM II) programmers. If you place the reset pin in the disable position with one or more areas disarmed, there must be an entry in the *Answer Disarmed* program item to use RAM II.

If you place the reset pin in the disable position when all areas are armed, there must be an entry in the *Answer Armed* program item. See *RAM Parameters* in the *D7212 Program Entry Guide* (74-06915-000).

Releasing the reset pin from the closed position resets the panel. The panel resets all its timers, counters, indexes, and buffers.

Changes to some program parameters require a reset before they become effective: Radionics recommends that you reset the panel after changing program parameters with the D5200 programmer. The D5300 (RAM II) programmer prompts you for a "RESET BYE" when a program change requires that the panel be reset.

Lock the Reset Pin Now

Locking the pin in the disable position allows you to power up the panel and charge the battery as you install the detection devices and command centers. Lock the pin down now.

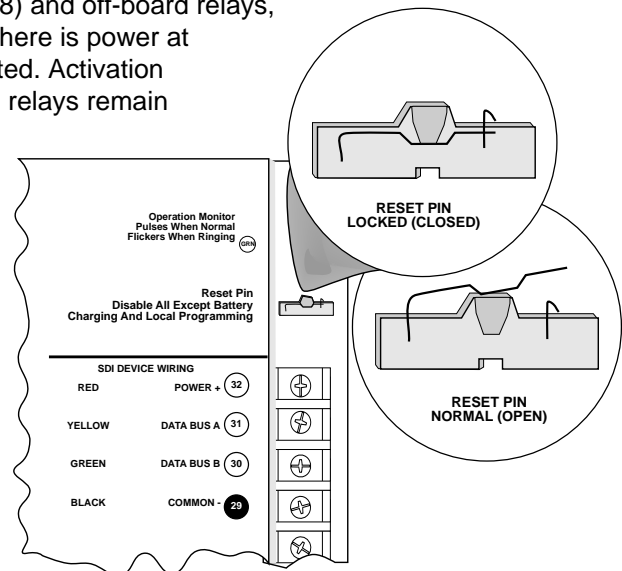

Figure 3: Reset Pin

Finishing the Installation

Earth ground and reset pin first: Make the earth ground connection to terminal 10 and lock the reset pin in the closed position if you haven't already done so.

Charge the Battery as You Finish

Connect the battery and then the transformer so that the panel can charge the battery as you finish the installation. See the *Power Supply* section for instructions.

On-board Buzzer Sounds at Power Up and Reset: The D7212 performs a series of self diagnostic tests of its hardware, software, and program at power up and at reset. The buzzer on the D7212 sounds during the tests. They take about 10 seconds to complete.

If the panel fails any of the tests, the buzzer continues sounding and a system trouble message appears at the command centers. See *Self Diagnostics* in the *Trouble Shooting* section for a description of each system trouble message.

Touch Terminal 10 first: If the on-board buzzer sounds briefly when you touch the panel, you're discharging any static charge you may be carrying to the panel. The panel may generate WATCHDOG RESET and/or PARAM FAIL events. See the *Trouble Shooting* section for a description of these events. Always touch terminal 10, the panel's earth ground connection, before beginning work on the panel.

Install and Wire Detection Devices

Install and wire detection devices and command centers at their locations throughout the premises. DO NOT make the connections at the panel end of the wiring yet.

The *On-Board Points* section of this manual contains instructions for wiring the on-board points to detection devices. The *Arming Devices* section contains instructions for wiring the command centers.

Instructions for wiring the off-board point POPIT sensor loops are found in the instructions packaged with the POPIT modules.

Install Modules and Relays

1. **Power Down First:** Power down the D7212 by unplugging the transformer and disconnecting the battery. Radionics recommends that you power down the D7212 when installing modules or relays, or when making wiring connections to the panel.
2. Install and wire any modules required for your installation as described in the module's installation instructions.

Instructions for the D8125 POPEX Module, the D8128A OctoPOPIT Module, the D8129 OctoRelay Module, the D811 Arm Status Relay Module, and the D128 Dual Phone Line Switcher appear in this manual.

See *Off-board Points* for D8125 and D8128A instructions. See *Relays* for D8129 and D811 instructions. See *Dual Line Transmitting* in the *Telephone Connections* section for instructions for the D128.

3. If you are using the power outputs at terminals 7 or 8, install a D136 relay in the appropriate sockets. See *Programmable Power Outputs* in the *Power Outputs* section for instructions.
4. If you are using a ground start phone system, insert a D136 relay in socket K6/J5 and set the ground start pin in the ground start position. See *Ground Start* in the *Telephone Connections* section.

Make the Telephone Connections

See *Telephone Connections*. If you are connecting the D7212 to a ground start phone system, you need to install D136 relay, see *Install Modules and Relays* on the previous page.

Connect the On-Board Points and Command Centers

Connect the on-board point and command center wiring to the D7212. See the *On-Board Points* and *Arming Devices* sections for instructions.

Power Up

Reconnect the battery and then plug in the transformer. Remember the buzzer sounds for 10 seconds when you first power up the panel.

Leave the reset pin locked down for now.

Yellow Charging Status LED doesn't go out: If the yellow charging status LED doesn't go out within 5 minutes of powering up the panel, the battery may be deeply discharged, or you may have connected too many powered devices to the panel. Combined continuous current draw for terminals 3, 8, and 32, and the Accessory Connector (J2) cannot exceed 1.4A. See the *Power Outputs* section for help.

Programming the Panel

If you haven't created a program for the panel, review the *D7212 Program Entry Guide* (74-06915-000). Check to be certain you have all the required accessory modules installed for the features you want to use.

Use the D5200 Programmer or the RAM II remote programmer to load your custom program into the panel.

Move the reset pin to the normal position. See Figure 3. The panel transmits reboot and battery reports to the receiver.

Install the Point Chart Label

Point chart label required for fire systems with verification points: You must install the point chart label for fire or combined fire/burglary systems using verification points.

Use the program record sheet to gather the information you need to fill out the point chart. Install the label on the enclosure door as shown in figure 2. To avoid smearing your entries on the chart, use the label's peel off backing to press the label in place.

Power Supply

Primary Power

Terminals

1

2

Primary (AC) Power Circuit

A 16.5 VAC, 40 VA internally fused transformer (Radionics model D1640) is the primary power source for the D7212. The AC power circuit provides 1.9 Amps of rectified AC power. The panel reserves 500 mA of this power for internal operations leaving 1.4 Amps for powered devices.

Transient suppressors and spark gaps protect the circuit from power surges. This protection relies on the ground connection at terminal 10. Make sure you connect terminal 10 to a proper ground. See *Connecting Earth Ground* in the *Installation* section.

AC Power Failure

The D7212 indicates an AC power failure when the power at terminals 1 and 2 is missing. The *AC Fail Time* program item sets the number of seconds that AC must be missing before the panel acknowledges the failure and the number of seconds after the power returns before the panel acknowledges the restoral of power.

You can program *AC Fail Time* from 1 to 90 seconds. The Radionics default sets *AC Fail Time* at 10 seconds.

Installing the Transformer

Do not short the terminals of the transformer: Shorting the terminals opens the internal fuse causing permanent failure. Connect the transformer to terminals 1 and 2 of the panel before plugging it into the power source.

Use 18 AWG (minimum) wire to connect the transformer to the panel. Wire length should be kept as short as possible. Maximum length is 50 feet.

Connect the battery and then plug in the transformer: Radionics recommends that you always connect the battery first and then plug in the transformer. Instructions for *Installing the Battery* appear on the next page.

Only plug the transformer into an unswitched, 120 VAC, 60 Hz power outlet. Secure the transformer to the outlet with the screw provided.

Never share the transformer with other equipment: Foreign grounds on the AC input damage the D7212 power circuit.

AC wiring can induce both noise and low level voltage into adjacent wiring. Route phone and sensor loop wiring away from any AC conductors, including the transformer wire. Route data wiring away from AC and phone wiring.

D8004 Transformer Enclosure required for fire systems: Use the D8004 Transformer Enclosure for the D1640 transformer in fire and combined fire/burglary applications.

Secondary (DC) Power

A 12V, 7 Ah sealed lead-acid rechargeable battery (Radionics D126) supplies secondary power for auxiliary and alarm outputs, and powers the system during interruptions in primary (AC) power.

Lead Acid Batteries ONLY: The D7212 charging circuit is only calibrated for lead-acid batteries. Do not use gel-cell or nicad batteries.

Extra Batteries Increase Back-up Time: To increase battery back-up time, connect a second 12V, 7 Ah battery in parallel to the first battery to form a 12V, 14 Ah battery. Use a D122 Dual Battery Harness to ensure proper and safe connection. You can use the D8132 Battery Charger Module to connect two additional batteries for a total of four. See the *D7212 Standby Battery and Current Rating Chart* in this manual for battery standby time calculations.

Installing the Battery

Place the battery upright in the base of the enclosure. Locate the red and black leads supplied in the literature pack. Connect the black battery lead to terminal 4, and then to the negative (-) side of the battery. Connect the red battery lead to terminal 5, and then to the positive (+) side of the battery.

Warning, High Current Arcs Possible: The positive (red) battery lead and Terminal 5 can create high current arcs if shorted to other terminals or the enclosure. Use caution when working with the positive lead and terminal 5. Always disconnect the positive (red) lead from the battery before removing it from terminal 5.

Replacement

Radionics recommends battery replacement every 3 to 5 years under normal use. Exceeding the maximum output ratings, or installing the transformer in an outlet that is routinely switched off, causes heavy discharges. Routine heavy discharges can lead to premature battery failure.

D8132 boosts battery backup: Adding a D8132 Battery Charger Module supports additional batteries of up to 36 Ah capacity if required.

Warning: The transformers for the D7212 and any D8132 modules connected to it must be powered from the same 120 VAC circuit. The D7212 supervises AC power by monitoring the power from the transformer connected to terminals 1 and 2. It cannot supervise the AC power for D8132 modules if their transformers are not plugged into the same AC circuit as the transformer for the panel.

Battery Supervision

When the battery voltage drops to 13.8 VDC, the yellow Charging Status LED lights. When the battery drops to 12.1 VDC the red Low Battery LED lights and the panel, if programmed for power supervision, transmits a BATTERY LOW report in the Modem II transmission format. It transmits a TROUBLE ZN 9 report in the BFSK format.

If the battery is missing or shorted, the red Low Battery LED flashes at the same rate as the green Operation Monitor LED. If the panel is programmed for power supervision, it transmits a BATTERY MISSING report in the Modem II transmission format, or TROUBLE ZN 9 report in the BFSK format.

Battery Supervision (Continued)

When battery voltage returns to 13.7 VDC the Low Battery LED goes out. If the panel is programmed for power supervision, it transmits a BATTERY RESTORAL report in the Modem II transmission format or RESTORAL ZN 9 report in the BFSK format. At 13.9 VDC the Charging Status LED goes out.

Investigate low battery reports right away: If primary (AC) power is off and the discharge continues, the panel becomes inoperative when the battery voltage drops below 10.2 VDC.

Battery Charging Circuit

Float Charge

The float voltage for the battery charging circuit is 13.9 VDC at a maximum current of 1.4 Amps. Deduct any continuous load for devices connected to the panel from 1.4 Amps to find the actual current available for charging.

Load Shed Relay protects battery: During an AC power loss the battery supplies all power to the security system. If the battery voltage falls below 10.2 volts during an AC power loss, a "load shed" relay isolates the battery from the panel and disables the panel. Load shed protects the battery from being damaged by deep discharge. When AC power restores, the load shed relay resets and battery voltage is again available.

Reset or power down required for shorted battery: If the D7212 determines the battery is shorted, it uses the load shed relay to disconnect the battery. You must reset or power down the panel after correcting the problem to reset the load shed relay and reconnect the battery.

Reset the panel by momentarily placing the reset pin in the disable position. See Figure 3. The red Low Battery LED continues to flash until you reset the panel.

A shorted battery condition is created either by a shorted cell inside the battery or by a short on terminals 4 and 5. A shorted battery may generate WATCHDOG RESET reports.

Battery Discharge/Recharge Schedule (No AC Power)

Discharge Cycle

AC OFF	AC fail report when AC fails if panel is programmed to report AC failure at occurrence.
13.9 VDC	Charging float level
13.8 VDC	Charging Status LED on
12.1 VDC	Low Battery & AC fail reports if programmed; Low Battery LED on
10.2 VDC	Battery load shed (processing functions continue if AC is present)

Recharge Cycle

AC ON	Load shed relay resets, battery charging begins, battery trouble and AC restoral reports sent.
13.7 VDC	Battery restoral reports sent, Low Battery LED off
13.9 VDC	Charging Status LED off, battery float charged

Charging Status and Low Battery LEDs

Charging Status LED (Yellow)

The yellow LED shows the charging status of the battery. Figure 4 shows its location.

- **Yellow LED off**
The yellow LED is off when the battery is fully charged.
LED off when battery is missing, shorted, or reversed: The charging LED is off when the battery is missing, shorted, or reversed, but the red Low Battery LED is flashing.
- **Yellow LED on**
A steadily lit yellow LED indicates the battery float voltage is below 13.8. If AC is present the battery is charging.

The yellow LED also comes on when the combined current draw from all outputs exceeds 1.4 Amps. This is normal under alarm conditions for non-fire systems when sirens or bells draw more than 1.4 Amps. If the LED comes on regularly for extended periods or doesn't go out, check the current draw for devices connected to the power outputs. See the *Power Outputs* section in this manual for instructions.

- **Yellow LED flashing once per minute**
The yellow LED normally flashes once per minute as the D7212 checks the battery.
- **Yellow and red LEDs flashing once per minute**
The yellow and red LEDs flash on once every minute when current draw for devices connected to the power outputs exceeds 1.4 Amps and the battery is missing.

Low Battery LED (Red)

The red LED shows the condition of the battery. Figure 4 shows the location of the LED.

- **Red LED off**
The red LED is off when the battery is fully charged. When battery voltage drops below 12.1 VDC, the red LED comes on. It goes out when battery voltage reaches 13.7 VDC.
- **Red LED on**
A steadily lit red LED indicates battery voltage has fallen below 12.1 VDC. The LED goes out when battery voltage reaches 13.7 VDC.
- **Red LED flashing (same rate as green LED)**
The red LED flashes with the green Operation Monitor LED when the battery is missing or shorted.

Reset required for shorted battery: If the D7212 detects a shorted battery, the battery remains disconnected and the red Low Battery LED continues to flash until you reset the panel.

No missing battery with D192A Using a D192A with a D7212, prevents the D7212 from recognizing a missing battery condition.

- **Red and yellow LEDs flashing once per minute**
The yellow and red LEDs flash once every minute when current draw for devices connected to the power outputs exceeds 1.4 Amps and the battery is missing.

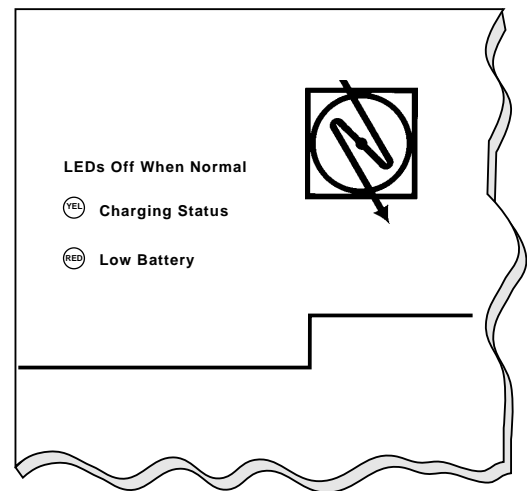

Figure 4: Charging and Battery LEDs

Power Outputs

Circuit Protection

Three self-resetting thermal circuit breakers protect the panel from short circuits on both the continuous and programmable power outputs. The circuit breakers are thermal rated and open at 3 to 5 Amps. If the panel is programmed for power supervision and short is sustained on one of the power outputs, the panel transmits a BATTERY LOW or BATTERY MISSING for Modem II, or TROUBLE ZN 9 for BFSK.

One thermal circuit breaker protects Terminal 3 - Auxiliary Power.

One breaker protects Terminal 6 - Alarm Power Output, Terminal 7 - Alternate Alarm Power Output, and Terminal 8 - Switched Auxiliary Power. A short on one of these terminals disrupts the power to the other two.

One circuit breaker protects terminal 32 - Power +.

Warning, Minimum Requirement for Wire Length: Connect powered devices to terminals 3, 6, 7, 8, and 32 with at least 5 feet of 22 AWG wire or 14 feet of 18 AWG wire. A D7212, with devices connected with shorter lengths of wire, may not operate properly if AC power is interrupted.

Available Power

The D7212 produces up to 1.4A of power at 10.2 VDC to 13.9 VDC for powered devices. The outputs listed below share the available power.

Terminal 3 - Auxiliary Power

Use this terminal to power devices requiring continuous power, such as the D8125, D8128A, and D8129 modules.

Terminal 6 (Relay A) - Alarm Power Output

Terminal 7 (Relay B) - Alternate Alarm Power Output

Use terminals 6 and 7 to power devices requiring power on alarm. See *Programmable Power Outputs*.

Terminal 8 (Relay C) - Switched Auxiliary Power

Use this terminal to power devices requiring a programmable power interruption. Command 47 or Alarm Verification interrupts the power. See *Programmable Power Outputs* in this manual.

Terminal 32 - Power +

Use this terminal to power SDI (Serial Device Interface) devices such as the D1255 Command Center and the D9131 Parallel Printer Interface.

Accessory Connector (J2)

The D128 Dual Phone Line Switcher connects to J2.

Continuous Power Outputs

Terminals

3

32

J2

Continuous Current Draw

The **continuous** current draw for powered devices connected to terminals 3, 8, and 32, and the Accessory Connector (J2) must not exceed 1.4A . Devices powered from these outputs must operate over a range of 10.2 VDC to 13.9 VDC.

Power restricted for fire and combined fire/burglary systems: Use the *Fire System Power Formula* to calculate the current available for fire and combined fire/burglary systems. See *Programmable Power Outputs*.

Programming

The power outputs at terminals 6, 7, and 8 are programmed as relays A, B, and C. All relays are programmed in the *Relays* module of the program. Relays are assigned a relay type, Fire Bell for example, when they are assigned to an area. Relays can be assigned to one or more areas.

The Radionics defaults set relay A (terminal 6) as an Alarm Bell output, relay B (terminal 7) as a Fire Bell output, and relay C (terminal 8) as a Verification/Reset output. The *D7212 Program Entry Guide* (74-06915-000) contains complete instructions for programming relays. Descriptions of the functional characteristics of each terminal appear on the next page.

See the *Bell Parameters* section of the program to set the Fire Bell, Alarm Bell output responses for relays. Four annunciation patterns: Steady, Pulsed, California Standard, and Temporal Code 3 are available.

Unexpected Output at Terminals 6, 7 and 8: If terminals 6, 7, and 8 don't provide the output you expect:

- Check the programming for relays A, B, and C in the *Relays* module of the program.
- Check the *Bell Parameters* section of the program to verify the Alarm and Fire Bell responses are programmed for the duration and pattern you expect.
- Check the *Point Assignments* to verify each point is programmed for the local response you expect.

Optional Relays Required

Install an optional D136 plug-in relay into socket J1 to enable the output at terminal 7. Install a D136 in socket J9 to enable the output at terminal 8. The relay sockets are under the faceplate as shown in Figure 5.

Relay Installation

Power down the D7212 before inserting the D136 relays. The plug-in relays are shorter than the sockets they plug into. See Figure 5. You can install them in either the left or right end of the socket.

Don't rely on relay labelling:

You shouldn't rely on the labelling to install D136 relays. Check for the side with three pins. The three pins go on the top side.

Incorrect insertion does not damage the relay or the D7212, however the related circuits do not function properly.

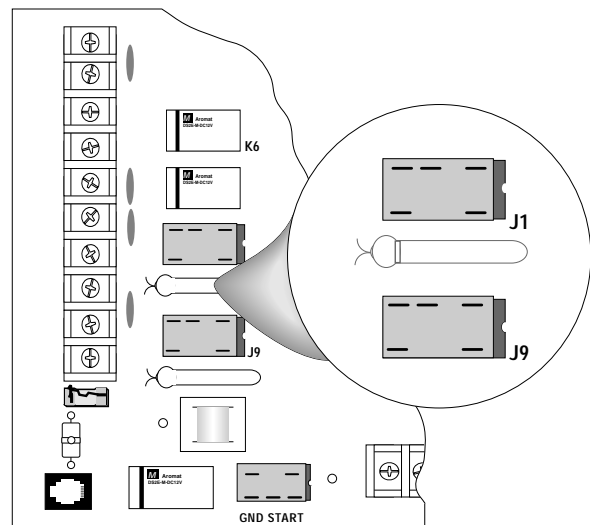

Figure 5: Relays for Terminals 7 and 8

Terminals 6 and 7

Terminals 6 (relay A) and 7 (relay B), provide positive (+) 10.2 VDC to 13.9 VDC power output when activated. Use the power at terminals 6 and 7 to power bells, siren drivers, piezo fire sounders, electronic horns, or other devices. Programming determines the format of the output and the conditions that activate it. One self-resetting circuit breaker protects terminals 6, 7, and 8 against shorts.

Available Power

The D7212 combines the 1.4A of primary power produced by the power supply with the secondary power source (the battery) to produce a total of 2.0A of **alarm** power at 10.2 to 13.9 VDC. Terminals 6 and 7 share the available alarm power.

Power restricted for fire and combined fire/burglary systems: Use the *Fire System Power Formula* below to calculate the current available for fire and combined fire/burglary systems.

Fire System Power Formula

To calculate the current available at terminals 6 and 7 for fire and combined fire/burglary systems:

1. Add together the current draws for all devices connected to terminals 3, 8, and 32, and the Accessory Connect (J2). This total is the total current required for the **Normal Standby Condition (NSC)**.
2. The current available for **Normal Standby Condition (NSC)** for the D7212 is 1.4A. Subtract the NSC current required calculated in step 1 from the NSC current available, 1.4A. The difference is the Alarm Current available for terminals 6 and 7.

In formula format:

$$\text{NSC current available} - \text{NSC current required} = \text{Alarm Current available}$$

Terminal 8

Terminal 8 provides continuous positive (+) 10.2 VDC to 13.9 VDC power. Relay C interrupts the power at terminal 8 when activated. Use terminal 8 to power smoke detectors or other devices that are reset by interrupting power. One self-resetting circuit breaker protects terminals 6, 7, and 8 against shorts.

Verification/Reset Relay

The D7212 default program sets relay C (terminal 8) as a verification/reset relay. See the *Relay Parameters* and *Point Assignments* modules in the D7212 Program Entry Guide (74-06915-000) for instructions on programming verification/reset relays and points.

Performing a CMD 47 at a command center produces a 5 second relay activation of verification/reset relays. The panel ignores verification/reset points during the 5 seconds of relay activation.

Telephone Connections

Registration

The Radionics D7212 Control/Communicator panel is registered with the Federal Communication Commission under part 68, for connection to the public telephone system using an RJ31X jack installed by your local phone company.

FCC Registration Number: AJ9USA-18808-AL-E

Ringer Equivalence: 0.1A 0.2B

Notification

Do not connect registered equipment to party lines or coin-operated telephones. You must notify the local telephone company and supply them with the following information before connecting the panel to the telephone network.

- The particular line you are going to connect the panel to
- Make (Radionics), model (D7212), and serial number of the panel
- FCC registration number and ringer equivalence for the panel (see *Registration above*)

Location

To prevent jamming of signals, wire the RJ31X jack before the in-house phone system to support line seizure. See Figure 6. Install the jack on the street side of the phone switch, wired ahead of any PBX equipment. Line seizure provides for a temporary interruption of normal phone usage while the communicator transmits data. After installation, confirm that the panel seizes the line, acquires dial tone, reports correctly to the receiver, and releases the phone line to the in-house phone system.

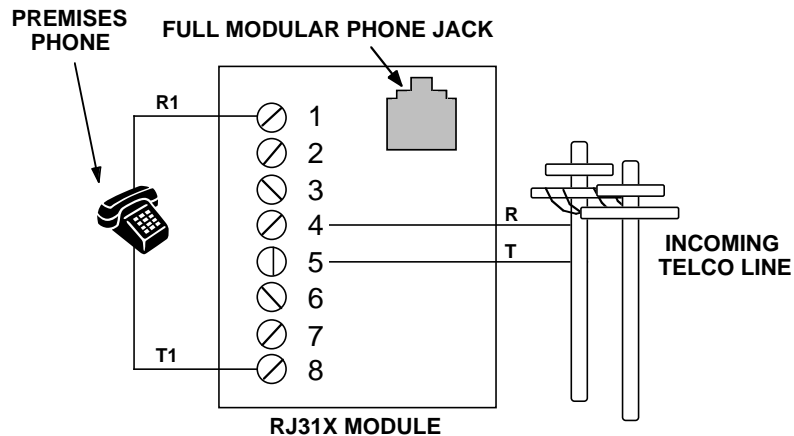

Figure 6: RJ31X Wiring

Phone Cord Connection

Connect one end of a D161 (8') or D162 (2') Telephone Cord to the D7212 TELCO Cord connector, J3, located on the bottom left corner of the D7212. See Figure 7. Connect the other end to the RJ31X jack.

Phone LED (Red)

The red Phone LED lights when the panel seizes the phone line and remains lit until the panel returns the phone line. See Figure 7 for the location of the red LED.

Operation Monitor LED (Green)

The green LED indicates the operation of the CPU (**C**entral **P**rocessing **U**nit). When the CPU is operating normally, the LED flashes 0.5 second on, 0.5 second off.

The green LED also serves as a ring indicator. See Figure 7 for the location of the LED. When there is ring voltage on the phone line (the phone is ringing), the green LED flickers at a faster rate for the duration of each ring. Ring voltage must reach a minimum of 45 VAC before the D7212 detects it.

Dialing Format

You can program the D7212 to use DTMF or pulse dialing. See *Phone Parameters* in the *D7212 Program Entry Guide (74-06915-000)*.

Phone Line Monitor

The D7212 panel has a built-in phone line monitor that tests the phone line for voltage and current. If you use the D128 Dual Phone Line Switcher to connect 2 phone lines to the D7212, the panel monitors both lines. The normal voltage on a telephone line is approximately 48 VDC (24 VDC for some phone systems). The phone line monitor senses trouble when the voltage on the line falls below 4.5 to 7.5 VDC, or in the off-hook condition when the current is 8 to 13 mA.

If the monitor senses trouble, it starts a programmable phone line trouble timer. The timer continues to run as long as the monitor senses trouble. It resets to zero when the panel senses a normal line. If the timer reaches the delay time in the *Phone Supervision* program item, it begins a phone line trouble response. Programming determines what the response is. See *Phone Parameters* in the *D7212 Program Entry Guide (74-06915-000)*.

The panel stops monitoring the phone line during its phone line trouble response. If the response includes sending a report, the panel does not resume monitoring until the report is acknowledged or it goes into communication failure.

Bad line may test OK: The telephone line monitor uses voltage and current levels to test the status of the phone line. In some instances a given telephone line may be out of service without affecting the voltage on the line. The phone line monitor can not recognize this trouble condition.

Phone Line Test Points

You can attach a telephone test set to the D7212 at the TELTEST points located above the TELCO jack on the lower left corner of the panel. See Figure 7.

Communication Failure

After 10 attempts to reach the receiver, the panel goes into communication failure. The panel clears any reports in its phone buffer. SERVC COMM FAIL appears in the display at command centers.

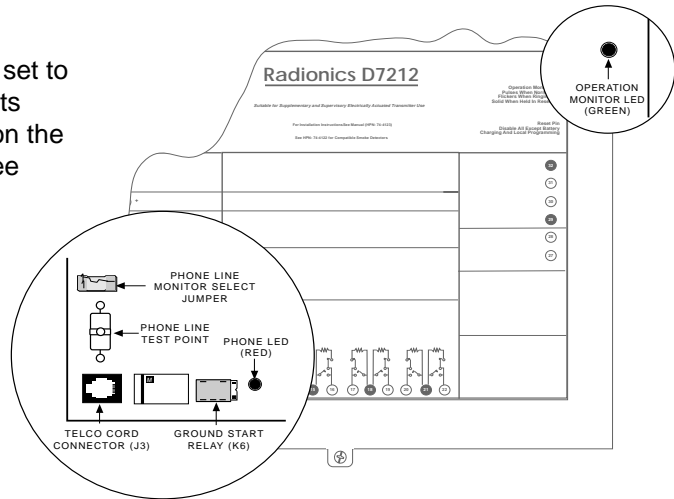

Figure 7: Telephone Connections

If you use the D128 Dual Phone Line Switcher, the D7212 makes 10 attempts on each line before going into communication failure.

Pressing Command 4 silences the tone. When communication restores (a report is acknowledged by the receiver), the display clears automatically. See *Phone Parameters* in the *D7212 Program Entry Guide* (74-06915-000) for reporting options.

Ground Start

Some telephone systems require a momentary ground input to initiate dial tone. To interface with a ground start system, insert a plug-in relay (D136) into socket K6/J5 and set the ground start jumper in the GND START position. Terminal 10 must be connected to an earth ground reference.

Relay Installation

Power down the D7212 before inserting the D136 relay into socket K6/J5. The relay socket is in the lower left corner as shown in Figure 8. The plug-in relay is shorter than the socket it plugs into. You can install it in either the left or right end of the socket.

Don't rely on relay labeling: You shouldn't rely on the labelling to install D136 relays. Check for the side with three pins. The three pins go on the top side.

Incorrect insertion does not damage the relay or the D7212, however the related circuits do not function properly. A ground start relay must not be inserted when dialing loop start.

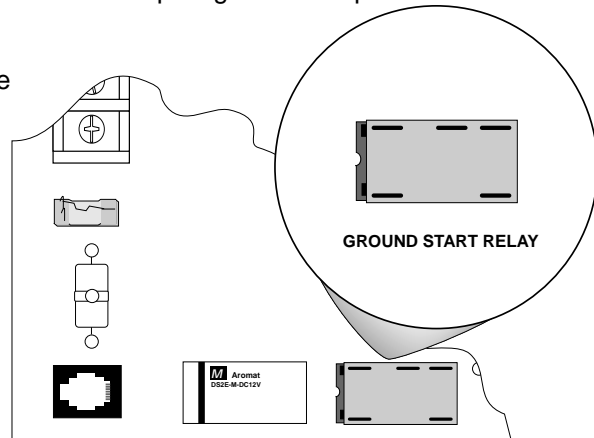
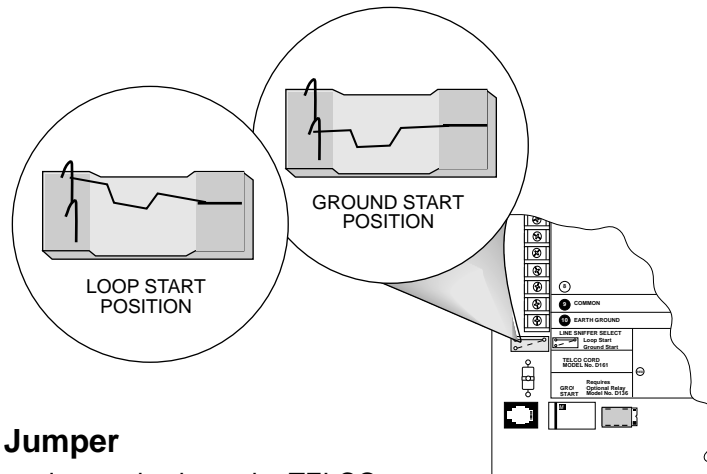

Figure 8: Ground Start Relay



Ground Start Jumper

The ground start jumper is above the TELCO connector and TELTEST point at the lower left corner of the panel. Set it in the ground start position. See Figure 9.

Figure 9: Ground Start Jumper

Ground start not for use in NFPA applications: You can not use ground start telephone systems for NFPA 71 Central Station Protective Signaling or NFPA 72 (Chap. 8) Remote Station applications.

D128 Dual Phone Line Switcher

Description

The optional D128 Dual Phone Line Switcher allows the D7212 to transmit reports over a primary or secondary phone line. The D7212 monitors both phone lines. You can hear a relay click as the D128 switches between the two phone lines.

Do NOT use the instructions packaged with the D128: The manual packaged with the D128 Dual Phone Line Switcher does not include complete instructions for connecting the module to the D7212 panel. Use the instructions that follow.

Set the ring count above 2 on answering machines: The D7212's RAM Monitor feature may not operate correctly if you connect an answering machine with a ring count of less than 2 rings, to a phone line used by the D128 module.

Operation

The D7212 always uses the primary phone line to initiate phone calls, unless it has been detected as faulty. See *Phone Line Monitor* in this manual for a description of the D7212's phone line monitor operation.

See the *Phone* section of the *Panel Wide Parameters* module of the *D7212 Program Entry Guide* (74-06915-000) for phone supervision and reporting options. You must set the *Two Phone Lines* prompt to YES to use the D128.

Primary Phone Lines, Primary Phone Numbers

Don't confuse primary phone lines with primary phone numbers: With the D128 Dual Phone Line Switcher installed, the D7212 uses two phone lines, primary and secondary, to dial up to four phone numbers.

These four phone numbers are designated as primary, backup, or duplicate. See *Phone Routing* in the *Panel Wide Parameters* module of the *D7212 Program Entry Guide* (74-06915-000) for a description of these designations.

The D128 uses the primary or secondary phone line to dial a primary, secondary, or backup phone number. After two failed attempts to reach the receiver on the primary phone line, the D7212 switches to the secondary line.

It alternates between the two phone lines, making two attempts on each line, until it makes ten attempts on each line. After ten failed attempts on each phone line, the D7212 goes into communication failure. See *Communication Failure* in this section.

Watchdog Feature

The D128 Watchdog circuit monitors the D7212's CPU (**C**entral **P**rocessing **U**nit) for proper operation. If the CPU fails, the buzzer on the D128 sounds in addition to the sounder on the D7212. The D128 only stops sounding when the D7212's CPU begins operating normally.

Installing the D128

1. Mount the D128 on the lower right side of the enclosure using the screws provided with the switcher. See Figure 2.
2. Connect the green lead from the D128 to terminal 1 on the D7212.
3. Connect the black lead from the D128 to terminal 9 on the D7212.
4. Plug one end of the ribbon cable provided with the D128 into J4 on the D128. Plug the other end into J2 (ACCESSORY) on the D7212.
5. Plug one end of the D162 (2') phone cord provided with the D128 into J3 on the D128. Plug the other end into J3 (TELCO) on the D7212.
6. Plug one end of a D161 (8') or D162 (2') phone cord into J1 on the D128. Plug the other end into the RJ31X for the primary phone line.
7. Plug one end of a D161 or D162 phone cord into J2 on the D128. Plug the other end into the RJ31X for the secondary phone line.

D128 Status LEDs

Four LEDs mounted on the front edge of the D128 module show the status of AC power for the D7212, the status of the two phone lines, and communication failure. See Figure 10.

AC Power LED

The green AC power status LED lights when there is AC power at terminals 1 and 2 on the D7212 panel.

Primary Fail LED

The yellow Primary Fail LED lights when the D7212's phone line monitor determines the primary phone line is faulted. See *Phone Line Monitor* in this section for a description of phone line monitor operation.

Secondary Fail LED

The yellow Secondary Fail LED lights when the D7212's phone line monitor determines the secondary phone line is faulted. See *Phone Line Monitor* in this section for a description of phone line monitor operation.

Communication Failure LED

The yellow Communication Failure LED lights when the D7212 is in communication failure. See *Communication Failure* in this section.

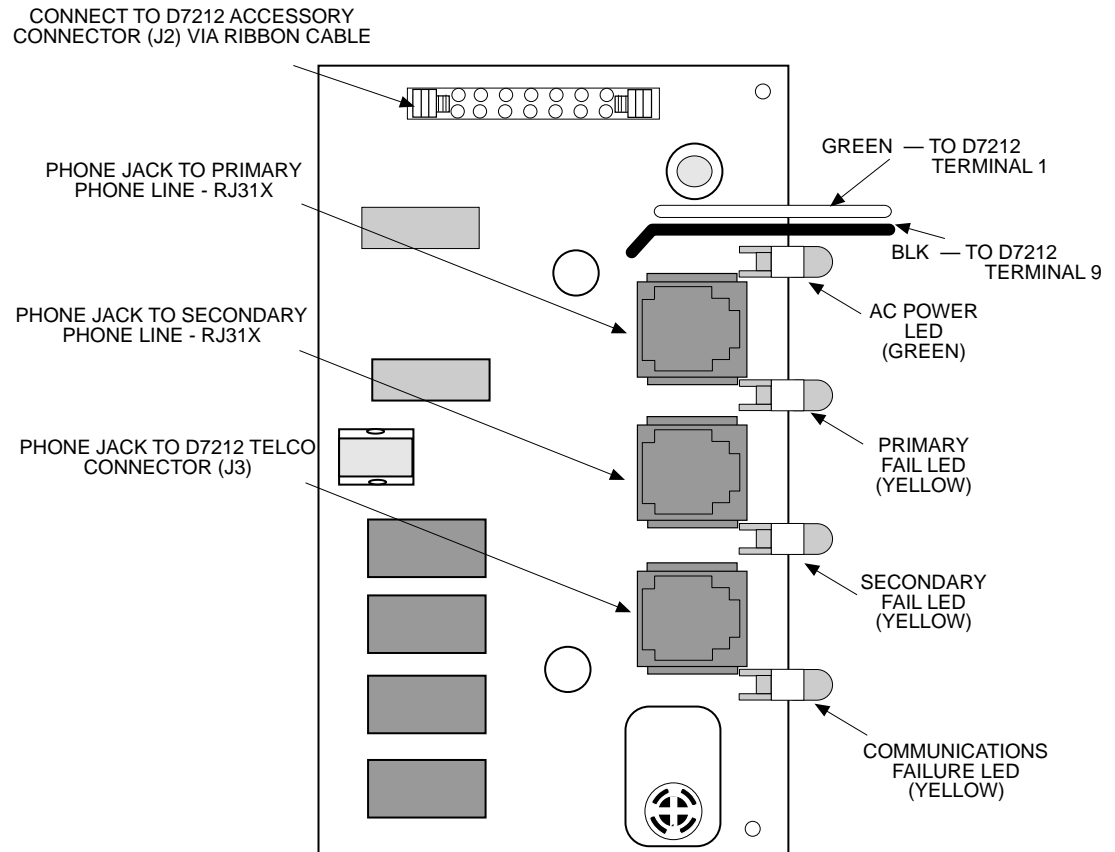

Figure 10: D128 Dual Phone Line Switcher

On-Board Points

Description

Terminals

11

to

22

The D7212 panel provides eight on-board points. Each point functions independently and does not interfere with the operation of the others. The panel monitors the sensor loops for normal, shorted, or open conditions between an input terminal (11, 13, 14, 16, 17, 19, 20, or 22) and any of the point common terminals (12, 15, 18, and 21). Programming for the point determines how the panel responds to those conditions. See the *D7212 Program Entry Guide (74-06915-000)* for point programming options.

Point Sensor Loops

When wiring the on-board points, install a 1k Ω resistor at the far end of the sensor loop to provide a reference for supervision. You can connect dry contact sensing devices in series (normally-closed) and/or in parallel (normally-open) to any of these loops.

The number normally-open and/or normally-closed detection devices each sensor loop can supervise is limited only by the resistance on the loop. Resistance on each sensor loop must be less than 100 Ω with the detection devices connected.

Ground shunts cause missed alarms: The possibility of “ground shunts” increases significantly if you don’t install the resistor at the end of the line. If you install the resistor for points 1 to 8 before a detection device on the sensor loop and the loop becomes grounded after the resistor, any devices beyond the ground are “ground shunted”. Alarm or trouble conditions beyond the ground are not seen by the panel.

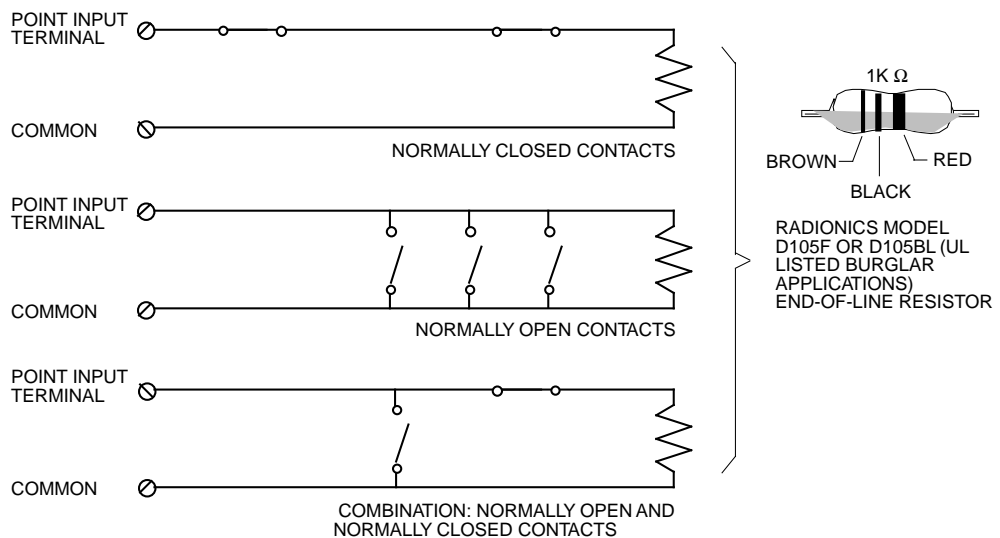

Figure 11: On-board Point Sensor Loop Wiring

Point Parameters

You can determine the condition of on-board points 1 to 8 by measuring the voltage across the point input terminal and one of the common terminals. The sensor loops must be connected and the 1k Ω end of line resistor in place.

Open Loop = Greater than 3.7 VDC, but less than 5.0 VDC.

Normal Loop = Greater than 2.0 VDC, but less than 3.0 VDC.

Shorted Loop = Greater than 0.0 VDC, but less than 1.3 VDC.

Point Response Time

The D7212 Control/Communicator scans both on-board and off-board point sensor loops every 300 milliseconds. The *Debounce Count* program item in the *Point Assignment* module determines point response time by setting the number of scans that a point must be faulted before the panel initiates an alarm.

The debounce count can range from 1 to 15. Therefore point response time ranges from 300 milliseconds to 4.5 seconds. The Radionics default for Debounce Count is 2.

Warning, increasing debounce count may cause missed alarms: If you increase the Debounce Count, detection devices may go into alarm and reset without exceeding the point response time.

Radionics recommends you leave the debounce count at 2 for all points.

Off-Board Points

Point (ZONEX) Buss

Terminals

23

to

27

You can use POPIT (**P**oint **o**f **P**rotection **I**nput **T**ransponder) modules to provide up to 40 off-board points, bringing the total number of points the D7212 can monitor to 48. Each off-board point requires a POPIT module.

POPITs connect to supervised two-wire data expansion loops run from POPIT to POPIT throughout the premises. Data expansion loops connect to a D8125 POPEX (**P**oint **o**f **P**rotection **E**xpander) module. POPEX module connects to the point buss on the panel, terminals 3 and 9 for power, and terminals 27 and 28 for data.

If a POPIT is disconnected from the expansion loop, a trouble message appears immediately. See the *D7212 Program Entry Guide* (74-06915-000) for programming options.

If you connect a POPIT that is programmed for a point number that does not appear in the program for the D7212 to the expansion loop, it appears as an extra point at the command centers when the point is faulted.

Placing a short on the data expansion loop generates a `PT BUS TROUBLE` report. The panel sees all points on the shorted expansion loop as shorted, and responds according to point programming.

POPIT modules monitor their sensor loops for three conditions, loop normal, loop open, and loop shorted. They report these three conditions to the D7212. A ground on a POPIT sensor loop reports as an open.

The D7212 uses point programming to interpret the sensor loop information reported by the POPITs and make the appropriate system response.

D8125 POPEX Module D8127 POPIT Modules

D8127 POPITs use the D8125 POPEX module to report to the D7212. The D8125 supports up to 40 POPIT points. The D7212 only annunciates activity for each POPIT, not each detection device connected to the sensor loop.

There are two versions of the D8127 modules. Both module enclosures are made of UL listed fire resistant material. D8127T modules contain tamper switches. D8127U modules come with an untampered cover. Unless the module is mounted in a tampered enclosure, UL requires D8127T modules for certificated accounts.

POPEXs manufactured prior to the expiration date (located on the packaging box) of X9434 may cause POPITs to report as missing after the AC has failed and after the panel goes into a low battery condition but before the panel goes into load shed. POPEXs manufactured after X9434 will not cause missing POPITs prior to load shed on an AC FAIL.

Listings

The D8125 POPEX and D8127 POPIT modules are UL listed for Local or Police Connected Burglar Alarm, Central Station Burglar Alarm, Household Burglar Alarm, Central Station Fire (NFPA 71), Local Fire (NFPA 72, Chapter 6), Remote Station Fire (NFPA 72, Chapter 8), Household Fire (NFPA 74) and Electrically Actuated Transmitter Applications. See the *Installation Guide for UL and Fire Applications* in this manual to determine the required equipment and enclosures for your application.

Installing the D8125 POPEX Module

Do not use the instructions packaged with the D8125: The manual packaged with the D8125 POPEX module does not include instructions for connecting the module to the D7212 panel. Follow the instructions below.

Save the D7212 POPIT Label Sheets: The D8125 is packaged with two sets of POPIT label sheets. One is marked *For use with D7212*. Save this set. You will use it later to label the POPITs.

Mounting

Follow the procedure below to install the D8125 in the enclosure with the D7212.

1. Align the D8125 POPEX module with any of the four mounting locations in the enclosure. See Figure 2.
2. Use the screws provided with the module to secure it in the enclosure.

Wiring the D8125 to the D7212

Follow the procedure below to wire one D8125 module to the D7212. See Figure 12.

Power down first: Power down the D7212 by disconnecting the positive (red) battery lead at the battery and unplugging the transformer.

Warning, reversed polarity damages the D8125: Make sure you correctly wire the D8125 AUX and GND terminals to the D7212.

For points 9 to 48:

1. Connect the GND terminal of the D8125 to terminal 9 on the D7212.
2. Connect the OUT terminal of the D8125 POPEX module to ZONEX IN 1, terminal 27 on the D7212.
3. Connect the IN terminal of the D8125 POPEX module to ZONEX OUT 1, terminal 28 on the D7212.
4. Connect the AUX terminal of the D8125 to terminal 3 on the D7212.

Wiring the D8125 to the D7212 (Continued)

Do not connect more than one D8125 to ZONEX terminals 27 and 28.

See *Wiring POPITs to the D8125* for instructions on connecting POPITs to the D8125 POPEX module.

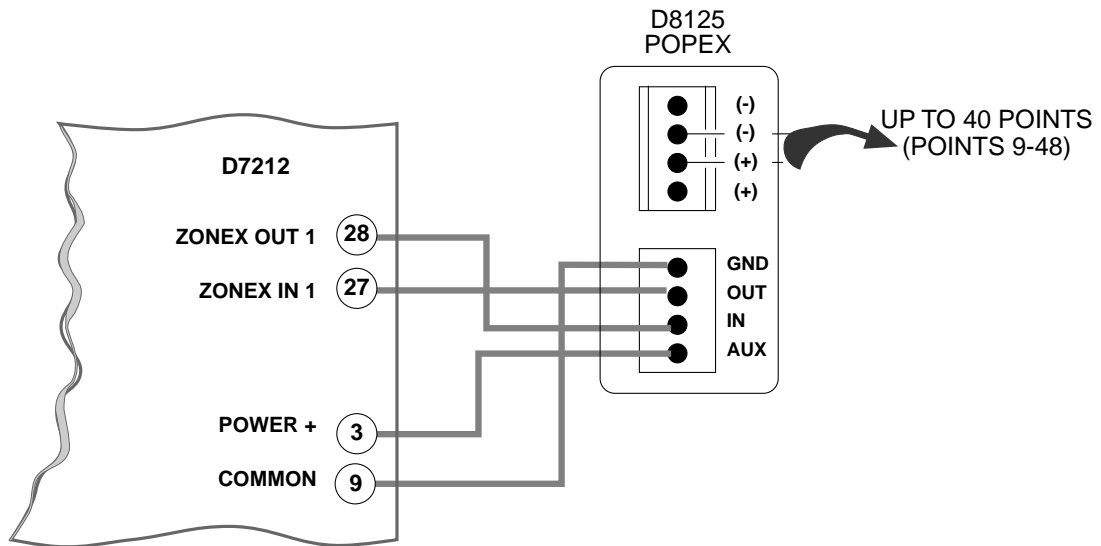

Figure 12: D8125 Connections

Wiring POPITs to the Data Expansion Loop

You can connect up to 40 POPITs to each D8125 module. Use one 2-wire data expansion loop or distribute the POPITs on up to three loops. Setting DIP switches on the POPIT modules assigns them to point numbers. See *POPIT Module Point Assignments*.

Review *Premises Wiring* in the *Installation* section of this manual to determine if shielded wire is required. Determine the required wire gauge for each data expansion loop using Table 1.

Combine data expansion loops: The maximum lengths shown in Table 1 are for data expansion loops connected to the same POPEX module combined.

Before installing the POPITs, make sure the resistance on the data expansion loop is no more than 60Ω.

Wiring POPITs together: Do NOT connect POPITs to each other in series, or with a T-tap. Doing so may cause random missing POPIT conditions. Follow the procedure below to connect POPITs to one another in parallel. Figure 13 shows a typical configuration.

1. Connect the positive (+) Data terminal from one POPIT to the positive (+) Data terminal on the next POPIT.
2. Connect the negative (-) Data terminal from one POPIT to the negative (-) Data terminal on the next POPIT.
3. Repeat steps 1 and 2 to connect all POPITs to the expansion loop. You don't need to wire the POPITs in any particular order on the loop. The switch setting on each POPIT assigns it a point number, regardless of its physical location.

Three inch clearance for tampered POPITs: Mount tampered POPIT Modules at least three inches apart to prevent the tamper magnets from interfering with each other.

Table 1: Data Expansion Loop Wire Specifications

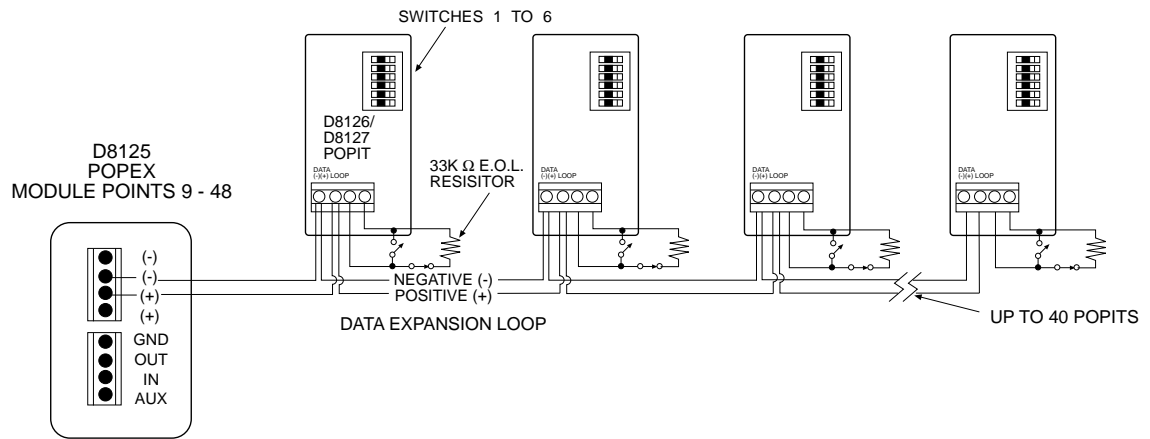

Figure 13: Typical Expansion Loop/POPIT Configuration

Wiring Data Expansion Loops to POPEX Modules

There are two positive (+) and two negative (-) data expansion loop terminals on each POPEX module. Follow the procedure below to connect the data expansion loops to the D8125 POPEX Module. See Figure 13. Remember, you can only connect a maximum of 40 POPITs to one D8125.

1. Connect the positive (+) Data terminal from the first POPIT on the data expansion loop to the D8125 module's positive (+) terminals.
2. Connect the negative (-) Data terminal from the first POPIT on the data expansion loop to the D8125 module's negative (-) terminals.

POPIT Sensor Loops

The number of normally-open and/or normally-closed detection devices each sensor loop can supervise is limited only by the resistance on the loop. Resistance on each sensor loop must be less than 100 Ω with the detection devices connected.

Certain UL and NFPA applications may limit the number of detection devices. Consult the appropriate UL or NFPA standards.

POPITs detect open, shorted, normal, and grounded circuit conditions on their sensor loops. They transmit the condition of their loops to the D7212. A ground on the sensor loop reports as an open condition. Each POPIT is programmed and transmits to the D7212 separately.

Terminate each POPIT sensor loop with the 33k Ω end-of-line resistor (Radionics D106F) included with each POPIT.

Radionics recommends you use twisted-pair wire in all POPEX/POPIT installations for both the data expansion loop wiring and the POPIT sensor loops. Run wires away from AC sources to prevent AC induction. If you suspect a noisy environment, use shielded cable. See *Premises Wiring* in the *Installation* section.

Point Assignments							
Popit Switch Setting	Translation	Point #	Point Index	Area Assign	Debounce	BFSK/Relay	Point Text
	100	01	3	1	2	1	P O I N T # 1 F I R E
	200	02	5	1	2	2	P O I N T # 2 P A N I C
	300	03	12	1	2	3	P O I N T # 3 D E L A Y
	400	04	24	1	2	4	P O I N T # 4 F O L L O W
	500	05	9	1	2	5	P O I N T # 5 I N S T A N T
	600	06	9	1	2	6	P O I N T # 6 I N S T A N T
	700	07	9	1	2	7	P O I N T # 7 I N S T A N T
	800	08	9	1	2	8	P O I N T # 8 I N S T A N T
123456	101	09		1	2	1	P O I N T # 9
1234 5-	102	10		1	2	1	P O I N T # 10
1234 -6	103	11		1	2	1	P O I N T # 11
1234 - -	104	12		1	2	1	P O I N T # 12
123- 56	105	13		1	2	1	P O I N T # 13
123- 5 -	106	14		1	2	1	P O I N T # 14
123- -6	107	15		1	2	1	P O I N T # 15
123- - -	108	16		1	2	1	P O I N T # 16
12- 456	109	17		1	2	1	P O I N T # 17
12- 45 -	110	18		1	2	1	P O I N T # 18
12- 4- 6	111	19		1	2	1	P O I N T # 19
12- 4- -	112	20		1	2	1	P O I N T # 20
12- -56	113	21		1	2	1	P O I N T # 21
12- -5 -	114	22		1	2	1	P O I N T # 22
12- - -6	115	23		1	2	1	P O I N T # 23
12- - - -	116	24		1	2	1	P O I N T # 24
1- 3456	201	25		1	2	2	P O I N T # 25
1- 345 -	202	26		1	2	2	P O I N T # 26
1- 34- 6	203	27		1	2	2	P O I N T # 27
1- 34- -	204	28		1	2	2	P O I N T # 28

Figure 14: D7212 Program Record Sheet

Point Assignments

Six switches on each POPIT assign the module to a point number. POPIT switch settings are found in the *Point Assignment* section of the *D7212 Program Sheet*. See Figure 14.

D7212 Program Record Sheet

The first column on the program record sheet contains the switch settings for the POPITs. Switches are numbered 1 to 6, left to right. Set switches whose number appears in the setting to the ON position. Set switches with a dash (-) in the switch position in the setting to the OFF position. See Figure 14.

The second column contains the translation of the point number into the D8112 ZONEX format. See *Point User Flag* in the *Panel Wide Parameters* module of the *D7212 Program Entry Guide* (74-06915-000) for an explanation of this feature.

The third column contains the point number as it is displayed at command centers. The fourth column contains the point index. See the *Point Index Parameters* module in the *D7212 Program Entry Guide* (74-06915-000) for an explanation of the point index.

The fifth column of the record sheet shows the area the point is assigned to. The sixth column shows the Debounce Count for the point. See *Debounce Count* in the *Point Assignments* module in the *D7212 Program Entry Guide* (74-06915-000).

The seventh column shows the BFSK report code. It is the point number reported for this point when the panel is using the BFSK format. The eighth column contains the text displayed at command centers for the point. The text is transmitted to the receiver when the panel is using the Modem II format.

POPIT Labels

Off-board points are numbered 9 to 48.

Four sheets of peel-off POPIT labels are supplied with the D8125 POPEX module. Use the sheet marked *Vertical Grid for POPEX #1* for points 9 to 48.

Each label has two parts. Place the smaller part, with just the point number on it, on the POPIT terminal block as shown in Figure 15. Place the larger part with the switch settings on the POPIT cover. Set the switches and cover the POPIT.

Do not program two POPITs for the same point number. After you program all the points, perform a walk test. The *Security System Owner's Manual* (74-06633-000) and the *Security System User's Guide* (71-06141-000) contain instructions for performing a walk test. If a point does not test, check the programming for a duplicated address.

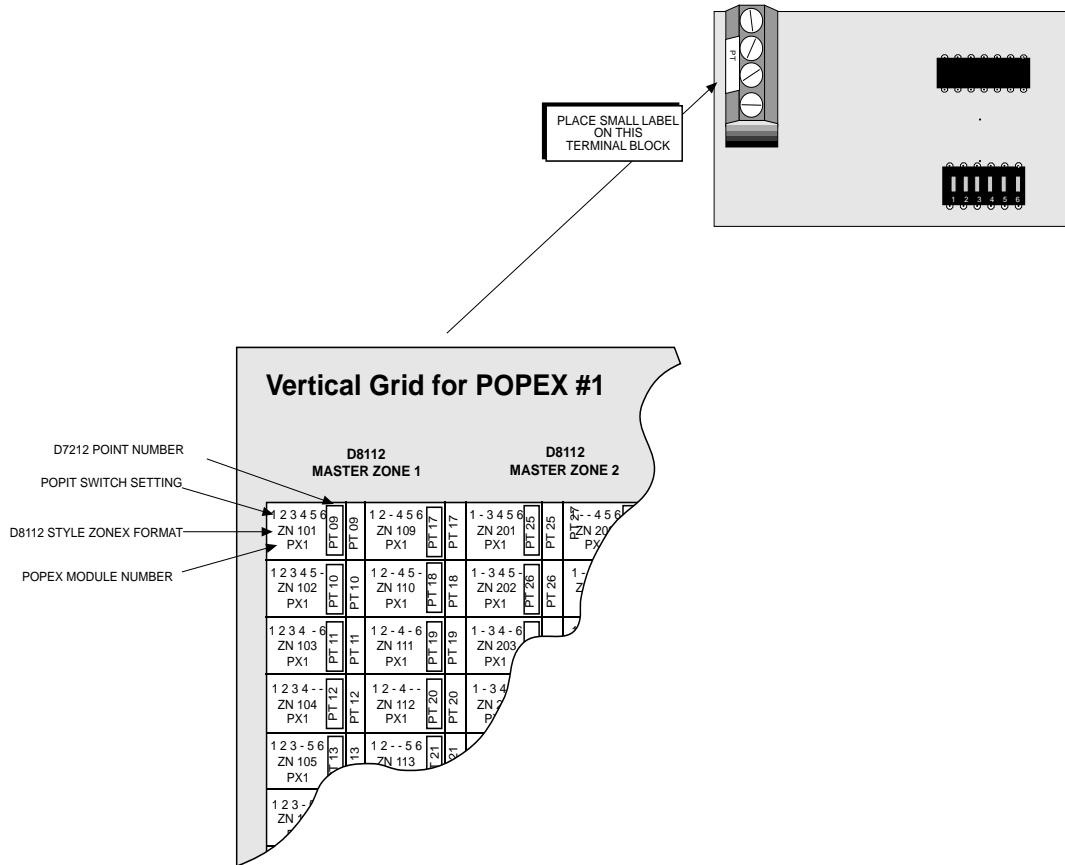

Figure 15: POPIT Labels

D8128A OctoPOPIT Module

Description

The D8128A OctoPOPIT Module combines the functions of the D8125 POPEX module and the D8127 POPIT modules to provide eight off-board points in a single module. You can use OctoPOPIT and D8125 POPEX modules on the same D7212.

Warning, Do not use D8128 modules, they are not compatible with the D7212, only use D8128A modules: Using D8128 modules may cause intermittent missing and restoral reports. Be sure to only use D8128A modules.

Review the *Power Outputs* section of this manual to be sure you provide enough power for the OctoPOPITs and other powered devices you wish to connect to your system.

Do not use the instructions packaged with the OctoPOPIT: The literature packaged with the OctoPOPIT is not for use with the D7212 panel. Use the instructions below.

Listing

The D8128A OctoPOPIT Module is UL listed for Local or Police Connected Burglary Alarm, Central Station Burglary Alarm, and Household Burglary Alarm applications. The D8128A is also suitable for fire supervisory applications, such as indicating circuit supervision (using the D192A Bell Circuit Supervision Module), sprinkler supervision, and valve tamper protection. Do not connect fire alarm initiating devices to the D8128A

You must use the D125B Powered Loop Interface Module or D129 Dual Class A initiation Circuit Module for fire initiation applications. Connect the initiating devices, smoke detectors for example, to the D125B powered loops or D129 Class A loops.

Connect the zone outputs on the D125B or D129 to the OctoPOPIT sensor loop inputs. The D125B or D129 and the OctoPOPIT must be mounted in the enclosure with the D7212 or in an enclosure connected to the D7212's enclosure by conduit not more than 20 feet in length.

Installing the OctoPOPIT

You can install the D8128A OctoPOPIT Module in the enclosure with the D7212, or in a separate enclosure up to 200 feet from the panel. If you mount the OctoPOPIT in a separate enclosure, use shielded cable to avoid electro-magnetic interference. See *EMI on Long Wire Runs* in the *Troubleshooting* section of this manual.

Tampered enclosures for UL certificated systems: Mount the D8128A in a tampered enclosure for UL certificated systems.

Mounting

Follow the procedure below to install OctoPOPITs in the enclosure with the D7212.

1. It is easier to set the switches on the D8128A before you mount it in the enclosure. See *Line Termination, Sensor Loop Switches, and Point Assignment Switches*.
2. Align the OctoPOPIT module with any of the four mounting locations in the enclosure. See Figure 2.
3. Use the screws provided with the module to secure it in the enclosure.

Use the D137 Mounting Bracket to install OctoPOPITs in enclosures with no module mounting locations available.

Wiring OctoPOPITs to the D7212

Follow the procedure below to wire D8128A OctoPOPIT Modules to the D7212. You can connect OctoPOPIT and POPEX module to the same Point Buss terminals. The modules wire in parallel. Remember you can never assign the same point number to more than one point.

1. **Power down first:** Power down the D7212 by disconnecting the positive (red) battery lead at the battery and unplugging the transformer.
2. Connect terminal 1 on the OctoPOPIT to terminal 9 on the D7212.
3. Connect terminal 2 on the OctoPOPIT to terminal 28 on the D7212 to assign point numbers from 9 to 48 to this OctoPOPIT. See *OctoPOPIT Point Assignments*.
4. Connect terminal 3 on the OctoPOPIT to terminal 27 on the D7212.
5. Connect terminal 4 on the OctoPOPIT to terminal 3 on the D7212.
6. See *OctoPOPIT Sensor Loops* for instructions on connecting devices to the OctoPOPIT's sensor loops.

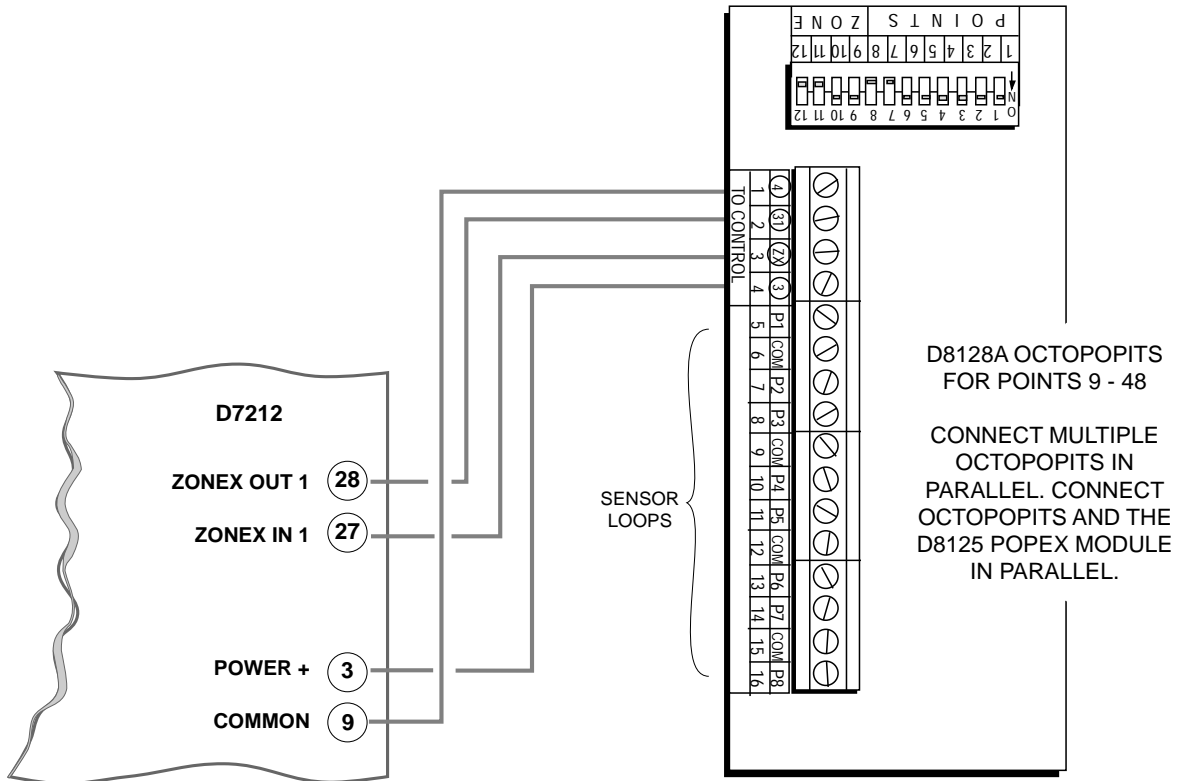

Figure 16: D8128A OctoPOPITs

Line Termination

If there is no D8125 POPEX module connected to ZONEX 1, terminals 27 and 28, set switch 12 on **only one** OctoPOPIT connected to those terminals to the on position.

If there is a D8125 POPEX module connected to ZONEX 1, terminals 27 and 28, set switch 12 on **all** OctoPOPITs connected to those terminals to the off position.

See Figure 16 for the location of the switches on the OctoPOPIT.

OctoPOPIT Sensor Loops

The number normally-open and/or normally-closed detection devices each sensor loop can supervise is limited only by the resistance on the loop. Resistance on each sensor loop must be less than 100Ω with the detection devices connected.

Certain UL and NFPA applications may limit the number of detection devices. Consult the appropriate UL or NFPA standards.

The OctoPOPIT detects open, short, closed, normal, and grounded circuit conditions on its sensor loops and transmits the conditions to the D7212. A ground on the positive leg of the sensor loop transmits a shorted condition for the point. Each sensor loop is assigned a point number and transmits to the D7212 separately. See *Point Assignment Switches* below.

Radionics recommends you use twisted-pair wire for the OctoPOPIT sensor loops to avoid EMI problems. Run wires away from the premises telephone and AC wiring. If you suspect a noisy environment, use shielded cable. See *EMI on Long Wire Runs* in the *Troubleshooting* section.

There are two rows of terminal numbers on the D8128A. See Figure 16. In the row closest to the terminal blocks, the positive outputs for the sensor loops are labeled *P1* to *P8*. Sensor loop outputs P1 and P2, P3 and P4, P5 and P6, and P7 and P8 share common terminals. The common terminals for each pair are labelled *COM*.

Sensor Loop Switches

Switches 1 to 8 activate each of the eight OctoPOPIT sensor loops. Setting the switch ON enables reports from that sensor loop. Setting the switch to OFF disables the loop. If you disable a sensor loop assigned to a point that the D7212 expects to see, the D7212 interprets it as a missing point.

Switch 1 corresponds to sensor loop 1 (terminal P1), switch 2 corresponds to sensor loop 2 (terminal P2), and so on.

Terminate each OctoPOPIT sensor loop with a 1k Ω end-of-line resistor. Attach a resistor even if you don't enable the loop. The OctoPOPIT comes with a Radionics D105BL resistor for each sensor loop.

Point Assignment Switches

Switches 9, 10 and 11 on the OctoPOPIT assign the sensor loops to D7212 point numbers. Table 2 shows the OctoPOPIT switch settings for point assignments. Each setting assigns point numbers to all eight sensor loops. Set the sensor loop switches (1 to 8) to OFF for points on the OctoPOPIT you don't intend to use.

Duplicated points do not function correctly: Take care not to duplicate point assignments. Points assigned to both an OctoPOPIT sensor loop and a POPIT, two OctoPOPIT sensor loops, or two POPITs, do not function properly.

**Table 2:
D8128A OctoPOPIT
Switch Settings**

D8128A Switches			D8128A Sensor Loop	D7212 Point # Connect D8128A to ZONEX
9	10	11		
On	On	On	P1 P2 P3 P4 P5 P6 P7 P8	9 10 11 12 13 14 15 16
On	On	Off	P1 P2 P3 P4 P5 P6 P7 P8	17 18 19 20 21 22 23 24
On	Off	On	P1 P2 P3 P4 P5 P6 P7 P8	25 26 27 28 29 30 31 32
On	Off	Off	P1 P2 P3 P4 P5 P6 P7 P8	33 34 35 36 37 38 39 40
Off	On	On	P1 P2 P3 P4 P5 P6 P7 P8	41 42 43 44 45 46 47 48

Off-board Relays

D8129 OctoRelay

The D8129 OctoRelay allows you to add relay outputs to your system in groups of eight. Up to 48 OctoRelay outputs (relay numbers 1 to 48) can be added to your system using 6 OctoRelays. Review the *Power Outputs* section of this manual to be sure you provide enough power for the OctoRelays and other powered devices you wish to connect to your system.

OctoRelays for relay numbers 1 - 48 connect to ZONEX terminal 28 on the D7212. See Figure 17.

You can assign alarm output, auxiliary relay, sensor reset, arming status, point status, alarm memory, or remote functions (Command 54) to the OctoRelay outputs individually. See *Relay Parameters* in the *D7212 Program Entry Guide* (74-06915-000) for programming details.

D8129 restricted for fire systems: The D8129 relay outputs are not supervised and can not be used in fire or combined fire/burglary installations for primary indicating devices.

Configuring the D8129 OctoRelay

Five switches on the OctoRelay determine the relay numbers for the eight relay outputs. Table 3 shows the switch settings.

Warning: Relay outputs may activate while setting the OctoRelay switches or programming the panel. You may wish to disconnect equipment connected to relay outputs while performing these functions.

Relay Outputs

Each OctoRelay output provides a Form C dry contact rated for 1.0A at 12 VDC. Normally-open, common, and normally-closed terminals are available for each relay output. When an individual output is activated, there is continuity between the normally-open and common terminals. When the output is not activated, there is continuity between the normally-closed and common terminals.

D7212 Relay Number	D8129 OctoRelay Switch Setting	On D7212, connect D8129 to
1 to 8	Off-On-On-On-On	ZONEX 1 Terminal 28
9 to 16	On- Off-On-On-On	ZONEX 1 Terminal 28
17 to 24	Off- Off-On-On-On	ZONEX 1 Terminal 28
25 to 32	On- On-Off-On-On	ZONEX 1 Terminal 28
33 to 40	Off- On-Off-On-On	ZONEX 1 Terminal 28
41 to 48	On- Off-Off-On-On	ZONEX 1 Terminal 28

Table 3: D8129 Switch Settings

Installation

Do not use the instructions packaged with the D8129: They do not include instructions for connecting the module to the D7212 panel. Follow the instructions below.

Set the switches on the OctoRelay before you install it in the enclosure. See *Configuring the D8129 OctoRelay*. You can install the OctoRelay in the enclosure with the D7212 (see Figure 2) or in an adjacent enclosure not more than 5 feet from the D7212. Use 16 to 22 AWG wire.

Follow the procedure below to install OctoRelays in the enclosure with the D7212.

1. Align the module with one of the mounting locations in the enclosure. See Figure 2.
2. Use the screws provided with the module to secure it in the enclosure.

Use the D137 Mounting Bracket to install OctoRelays in enclosures with no module mounting locations available.

Wiring Connections

Power down the panel to connect OctoRelays as shown in Figure 17. Note that OctoRelays for relay numbers 1 to 48 connect to ZONEX terminal 28 on the D7212.

Only one OctoRelay is shown wired to each ZONEX bus in Figure 17. Wire additional OctoRelays in parallel. Review the *Power Outputs* section of this manual to be sure you provide enough power for the relays.

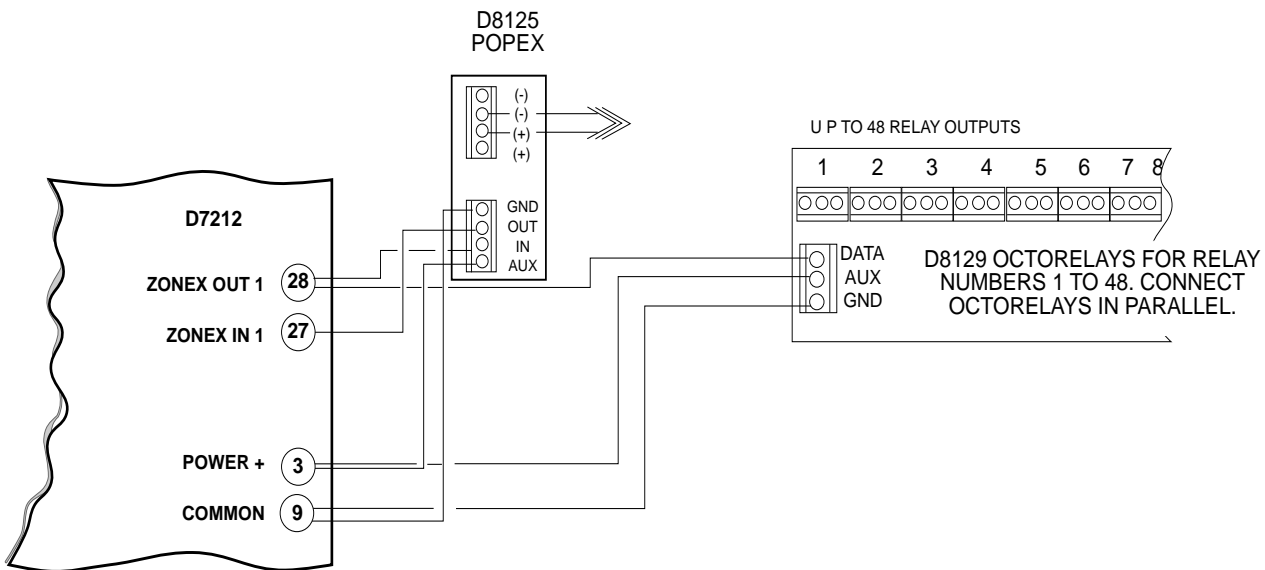

Figure 17: D8129 OctoRelay Connections

Arming Devices

Description

Command centers, maintained or momentary contact keyswitches, or a combination of the two are used to arm and disarm areas. The D7212 panel may contain up to 8 areas. See the *Introduction* section for a description of areas.

D1255 Command Centers

Terminals

29 to **32**

The Radionics D1255 Command Center is a 4-wire powered device used to arm and disarm areas, annunciate complete system status, initiate system tests, and control many functions of the D7212 security system.

The D7212 can supervise up to eight command centers. The panel transmits a serial device trouble report, SDI FAILURE in the Modem II format or TROUBLE ZN D in the BFSK format, if it loses communication with a supervised command center. SERVC KEYPAD appears at all other command centers connected to the system.

You can connect up to 32 command centers to the D7212 but they all can not be supervised. The number of supervised command centers, number of areas, and the available power determine the total number of command centers you can connect to the D7212. See *Command Center* in the *D7212 Program Entry Guide* (74-06915-000) for complete programming details on command center options.

CALL FOR SERVICE appears in the display of any command center that loses communication with the panel.

See the *Security System Owner's Manual* (71-06633-000) or *Security System User's Guide* (71-06141-000) for operational information.

Assigning the D1255 an Address

Switches on the D1255 assign an address (1 to 8) to the command center. The address determines if the command center is supervised, the command center's scope, and what area the command center is assigned to. See *Command Center Assignment* in the *D7212 Program Entry Guide* (74-06915-000) for a complete description of addresses.

Table 4 shows the correct switch setting for each address.

	Switch					
	1	2	3	4	5	6
Address #1	ON	ON	ON	ON	ENCODING TONE ON/OFF	ON
Address #2	OFF	ON	ON	ON		ON
Address #3	ON	OFF	ON	ON		ON
Address #4	OFF	OFF	ON	ON		ON
Address #5	ON	ON	OFF	ON		ON
Address #6	OFF	ON	OFF	ON		ON
Address #7	ON	OFF	OFF	ON		ON
Address #8	OFF	OFF	OFF	ON		ON

Table 4: D1255 Address Settings

Installation

Consult the *D1255 Installation Instructions* (74-06819-000) for installation and mounting instructions. Command centers connect to the D7212 panel in parallel as shown in Table 5.

D7212		Command Center	
Terminal	Function	Wire Color	Function
32 *	POWER +	Red	12 VDC
31	DATA BUS A	Yellow	Data-In
30	DATA BUS B	Green	Data-Out
29	COMMON	Black	Common

*Connect with at least 5' of 22 AWG wire (14' of 18 AWG wire)

Table 5: D1255 Connections

Switching the green and yellow wires affects other command centers: Incorrectly connecting the green wire from the command center to the D7212's terminal 31 and the yellow wire to terminal 30, causes other command centers connected to the panel to go blank and/or sound random beep tones.

You can connect a maximum of 15,000 feet of 22 AWG wire **for all command centers and printer modules combined** to the data bus, terminals 30 and 31. You can connect parallel wire runs from the D7212 to each device, run wire device to device, or combine the two.

Extra power needed for more command centers: The D1255 Command Center draws 104 mA when it is idle. It draws 206 mA with the back lighting for the keys lit and the sounder activated. Review the *Power Outputs* section to determine the total power output requirements for your system.

You may need to add one or more D8132 Battery Charger/Power Supply Modules for the number of command centers you want to use. Figure 19 shows the D8132 powering command centers in a stand-alone configuration.

For UL certificated accounts use a UL listed power supply. The D8132 is not UL listed as a stand-alone power supply.

D7212 and D8132 (or other power supply) must share COMMON: Note that Figure 19 shows the common from the D8132 module connected to both the command centers' common and the common on the D7212.

A stand-alone power supply powering any device connected to the D7212 must also be connected to a common terminal on the D7212. Do not connect the stand-alone power supply to earth ground other than terminal 10 on the D7212.

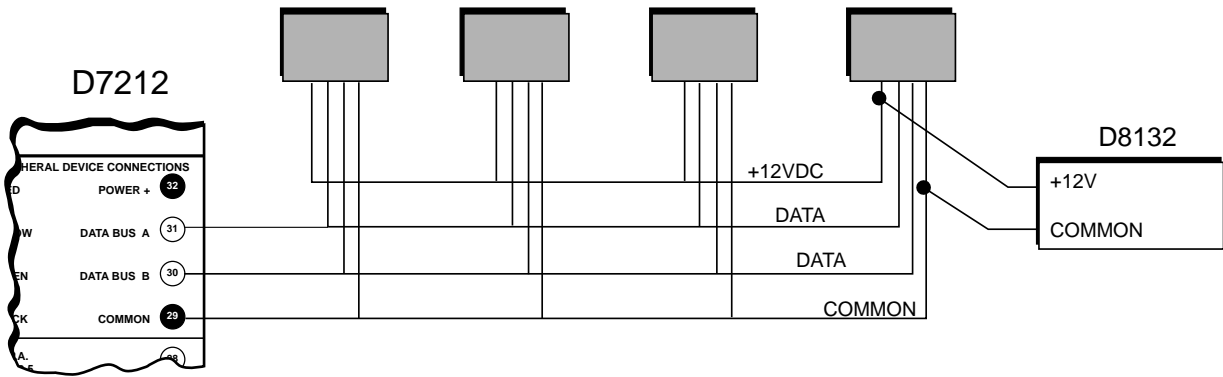

Figure 19: Power at Command Centers

D720 Command Center

For D720 Command Center operation and installation instructions, see the *D720 Operation and Installation Instructions* (74-06918-000).

D268/D269 Independent Zone Control D279 Independent Zone Control

You can program any *on-board* or *OctoPOPIT* point so that the D268/D269 or D279 Independent Zone Control operates as independent point control (arms and disarms the point).

See the *Point Assignments* in the *D7212 Program Entry Guide* (74-06915-000) for programming information. See the *D268/D269 Operation and Installation Instructions* (74-04758-000) or the *D279 Operation and Installation Instructions* (74-04993-000) for wiring and operation instructions.

Keyswitch

Description

You can connect a maintained or momentary contact arming station (keyswitch) to master arm/disarm any of the areas in the D7212. The keyswitch is connected to an on-board or off-board point's sensor loop. Relays can be programmed to activate arming status LEDs for keyswitch arming stations. See the *Relays* section of the *D7212 Program Entry Guide* (74-06915-000).

Programming

See the *Point Assignments* section of the *D7212 Program Entry Guide* (74-06915-000) for the correct programming for points used for keyswitches.

Installation

For maintained switches, connect the end-of-line resistor for the point at the keyswitch so that the switch opens the circuit when it operates. A short on the circuit produces an alarm if the area is armed and a trouble if it is disarmed. See Figure 20.

For momentary switches, connect the end-of-line resistor for the point at the keyswitch so that the switch shorts the resistor when it operates. An open on the circuit produces an alarm if the area is armed and a trouble if it is disarmed. See Figure 20.

Keyswitch Operation

Maintained Contact

If you program the point the keyswitch is connected to for a maintained contact, an open on the arming circuit arms the area. All faulted points are force armed, regardless of the entry in the *FA Bypass Max* program item. Returning the circuit to normal disarms the area. See *Area Wide Parameters* and *Point Assignments* in the *D7212 Program Entry Guide* (74-06915-000).

Momentary Contact

If you program the point the keyswitch is connected to for a momentary contact, shorting the arming circuit toggles the area's arming state between armed and disarmed. All faulted points are force armed, regardless of the entry in the *FA Bypass Max* program item. See *Point Assignments* in the *D7212 Program Entry Guide* (74-06915-000).

Silencing the Bell

To silence the bell (stop Alarm Bell output) if the system is armed, operate the keyswitch to disarm the area. If the area is disarmed, operate the keyswitch once to start the arming process and silence the bell. Operate it a second time to stop the arming process.

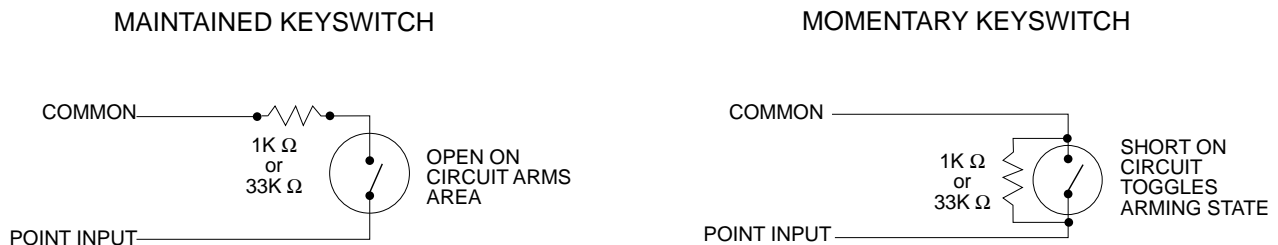

Figure 20: Keyswitch Wiring

Programmer and Accessory Connections

Programmer Connector (J7)

The procedure below shows you how to connect and disconnect the programmer. Refer to *D5200 Programmer Operation Manual (74-06176-000)* for complete information on using the D5200 programmer.

1. **Panel is operational during programming:** Except when the programmer is sending or receiving, the D7212 is functional while the programmer is connected to it. It will transmit reports as programmed.

Locking Reset Speeds Programming: If you have supervised command centers or other supervised devices connected to the Data Bus (terminals 30 and 31), locking the Reset Pin will speed communication between the panel and the D5200.

Radionics recommends that you lock the Reset Pin in the DISABLE position to prevent reports from being transmitted while you are programming. See Figure 21.

On-board relays (terminals 6, 7, and 8) and off-board relays, deactivate when the panel is reset. There is power at terminal 8 when the relay is deactivated. Activation interrupts power at that terminal. The relays remain deactivated while the Reset Pin is locked in the disable position.

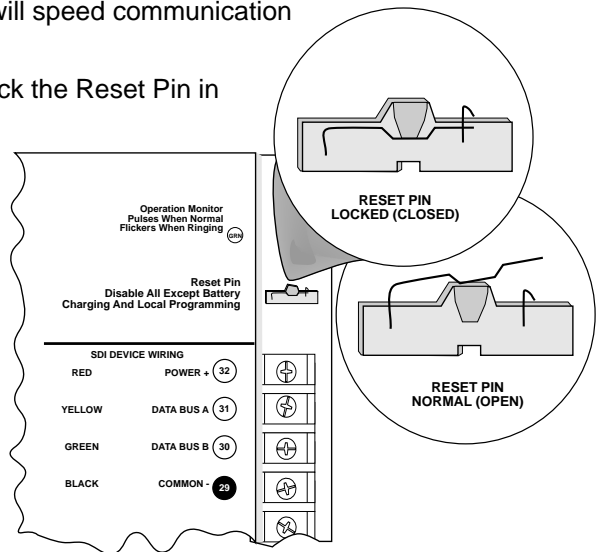

Figure 21: Reset Pin

2. Plug the D5200 Data/Power cord into the programmer connector (J7).
3. Advance the D5200 display to a D7212 product handler. See *D5200 Programmer Operation Manual (74-06176-000)*.

Troubles after 30 seconds: If you don't enter the D7212 handler within 30 seconds of connecting the programmer, supervised SDI devices (command centers, printer interface, etc.) connected to the D7212 generate SDI trouble reports.

Once the panel generates the SDI trouble reports all command centers, both supervised and unsupervised, stop responding to key strokes. Entering the D7212 handler or disconnecting the programmer returns the command centers to normal operation.

4. Perform the desired programming function (send or receive program).
5. Disconnect the programmer.
6. Changes to some program parameters require a reset before they become effective.

Reset Recommended: Radionics recommends that you reset the panel after changing program parameters with the D5200 programmer.

If you locked down the reset pin in step 1, release it now to reset the panel. If you didn't lock the rest pin, momentarily close it now to reset the panel. See Figure 21.

Remember On-board relays (terminals 6, 7, and 8) and off-board relays, deactivate when the panel is reset. There is power at terminal 8 when the relay is deactivated. Activation interrupts power at that terminal. The relays remain deactivated while the Reset Pin is locked in the disable position.

Remember that the panel's on-board buzzer sounds for 10 seconds whenever you reset the panel.

Programmer Access Reports

If you send a program to the panel, the panel sends a `PROG ACCESS OK` report ten seconds after you exit the handler or when you disconnect the programmer.

If you make 3 consecutive attempts to send or receive a program with an invalid DataLock code, the panel sends a `PROG ACCESS BAD` report. Successfully sending or receiving a program, or powering down the panel, resets the counter.

Accessory Connector (J2)

Use the **Accessory Connector (J2)** to connect the Radionics D7212 to the D128 Dual Phone Line Switcher. The Accessory Connector is on the bottom right corner of the I/O board. See Figure 22. The D128 allows the D7212 to use two telephone lines to transmit reports.

See *D128 Dual Phone Line Switcher* in the *Telephone Connections* section of this manual for installation and operating instructions.

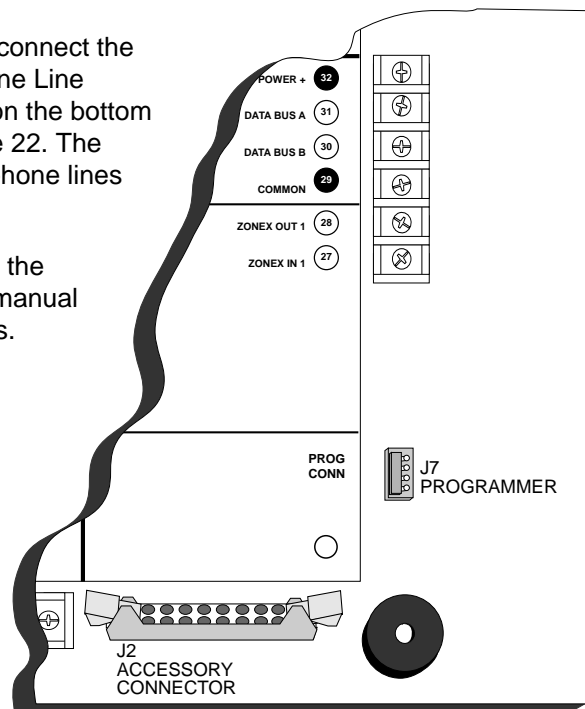
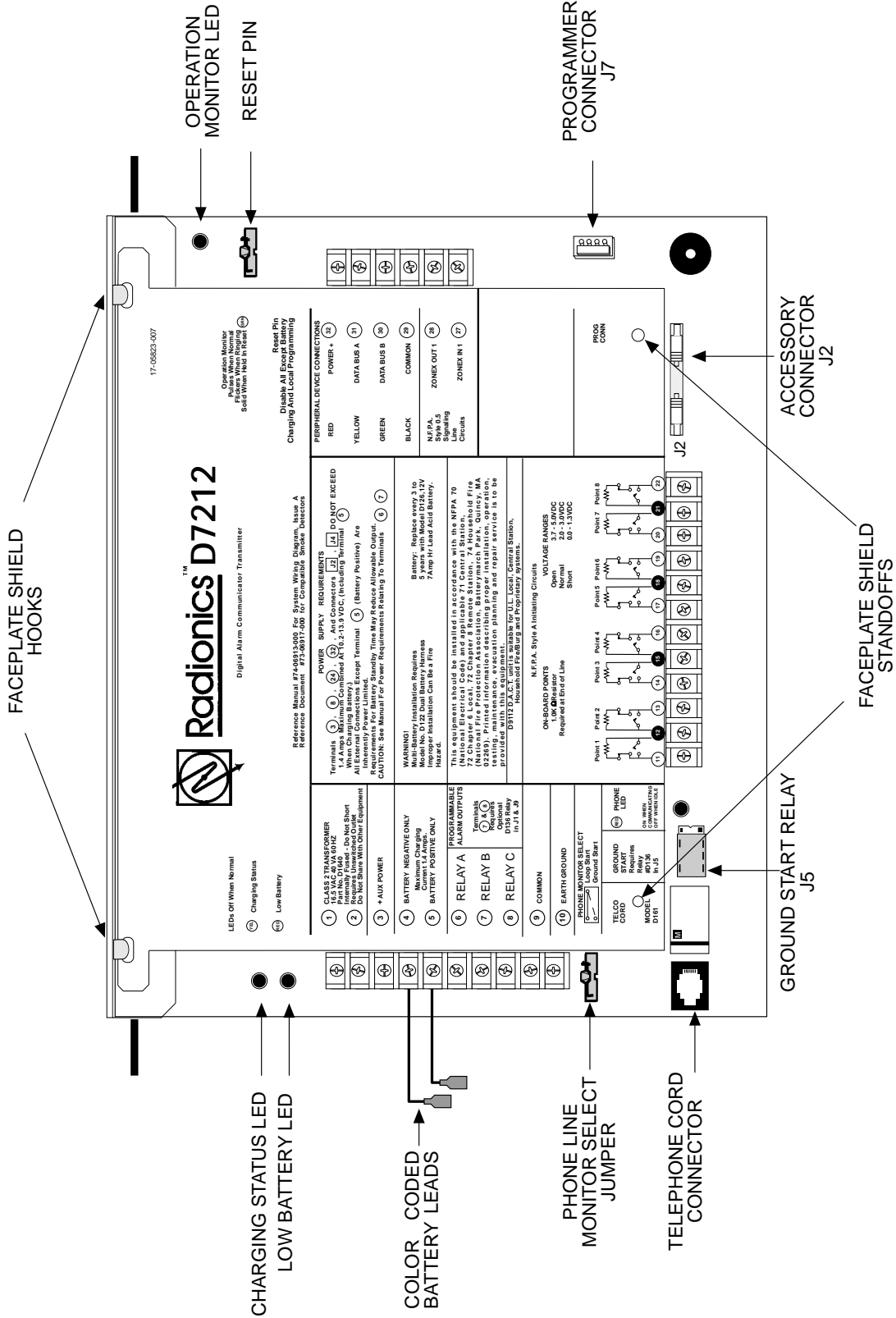

Figure 22: Programmer and Accessory Connections

D7212 Faceplate



Quick Reference Terminal Description

Terminal	Name	Description
1, 2	CLASS 2 TRANSFORMER	Connect 16.5 VAC, 40 VA transformer for primary power supply.
3	+ AUX POWER	Supplies up to 1.4A at 10.0 VDC to 13.9 VDC to powered devices. Use terminal 9 for common.
4	BATTERY NEGATIVE ONLY	Connect 12V, 7Ah rechargeable lead acid type battery's negative terminal (-) to terminal 4.
5 (+)	BATTERY POSITIVE ONLY	Connect 12V, 7Ah rechargeable lead acid type battery's positive terminal (+).
6 (+)	+ STEADY OR PULSED	Supplies up to 2 A at 10.0 VDC to 13.9 VDC for steady or pulsed alarm output. Use terminal 9 for common. Programmed as Relay A. Shares circuit breaker with terminals 7 and 8.
7 (+)	+ ALTERNATE	Supplies up to 2 A at 10.0 VDC to 13.9 VDC for steady or pulsed alarm output. Use terminal 9 for common. Programmed as Relay B. Shares circuit breaker with terminals 6 and 8. D136 Plug-in Relay required: Install a D136 in socket K3 for output at terminal 7.
8 (+)	+ SWITCHED AUX POWER	Supplies up to 1.4 Amps at 10.0 VDC to 13.9 VDC. Use terminal 9 for common. Programmed as Relay C. Continuous output interrupted by CMD 47 or alarm verification. Shares circuit breaker with terminals 6 and 7. D136 Plug-in Relay required: Install a D136 in socket K1 for output at terminal 8.
9	COMMON	Terminal 9 is common for Auxiliary Power, Alarm Power, Alternate Alarm Power, and Switched Aux Power (terminals 3, 6, 7, and 8).
10	EARTH GROUND	Connect to earth ground. A cold water pipe or grounding rod is preferred. Do not connect to telephone or electrical ground.
11, 13, 14, 16, 17, 19, 20, 22	ON-BOARD POINTS (Inputs)	Connect normally open and/or normally closed detection devices to loop wiring. 1 k Ω resistor required at end of loop.
12, 15, 18, 21	ON-BOARD POINTS (Common)	Loop returns for on-board points.
27 28	ZONEX IN 1 ZONEX OUT 1	Connect ZONEX module for points 9 to 48 and Octorelay modules for relays 1 to 48 to these terminals.
29 (-)	COMMON	Common terminal for SDI devices
30 31	DATA BUS B DATA BUS A	Terminals 30 and 31 are a two wire bus that drives the command centers, printer interface, and other SDI devices.
32 (+)	POWER +	Power for command centers, printer interface and other SDI devices. This separate protected power output for SDI devices is not affected by shorts on any other terminal.

Installation Guide for UL and Fire Applications

Listings and Approvals

Fire

UL

Underwriters Laboratories lists the D7212 Control/Communicator as a Signal System Control Unit for:

Central Station, Local, Auxiliary, Remote Station, and Household Fire Warning.

CSFM

Approved by the California State Fire Marshal.

NYC-MEA

Approved by New York City's Materials and Equipment Acceptance System.

Factory Mutual (FM)

Submitted for evaluation by Factory Mutual.

Burglary

UL

Underwriters Laboratories lists the D7212 Control/Communicator for:

Central Station, Local, Police Connect, Mercantile Safe and Vault, and Grade A Household systems.

Department of Defense (DOD)

The D7212 has been granted approval for Department of Defense (DOD) installations in Sensitive Compartmented Information Facilities (SCIF).

Introduction

The *D7212 System Chart* references components evaluated and listed by Underwriters' Laboratories for compatibility with the D7212 Control/Communicator. These components meet the basic system requirements for the applicable standard.

The *System Wiring Diagram, Issue A* shows the relationship between the D7212 panel and the accessory components referred to in the *D7212 System Chart*.

Optional Compatible Equipment

You can use UL listed components that do not require evaluation for electrical compatibility in many applications when installed according to the manufacturer's instructions.

Burglary Applications

You can use UL listed burglary alarm sensors that do not require evaluation for electrical compatibility in burglary applications. In some cases you must use a UL listed Radionics interface module in conjunction with the sensors. Consult the individual component specification and installation documents to determine suitability.

- The **D6103** enclosure is designed for small installations that don't require add-on modules. (See the *D7212 System Chart* for acceptable applications.)
- The **D8103** enclosure is suitable for residential fire and/or burglary installations and commercial burglary applications that do not require attack resistance or approval by Factory Mutual or NYC-MEA. (See the *D7212 System Chart* for acceptable applications.)
- The **D8108A** is attack resistant. It is intended primarily for UL commercial burglar alarm and mercantile safe and vault applications requiring a local bell. You can use the D8108A in any burglar or fire alarm application where the D8103 or D8109 enclosure is suitable. UL lists the D8108A for all commercial fire alarm applications. The D8108A is approved by Factory Mutual, California State Fire Marshal, and the New York City Materials and Equipment Acceptance System.

Test weekly: UL Standard 1023 requires a weekly test for residential burglary applications.

Fire Applications

You can use UL listed fire initiating devices not requiring electrical compatibility evaluation in any application. For example: 4-wire smoke detectors, heat detectors, water flow switches, and manual pull stations are suitable fire initiating devices. Consult the individual component specification and installation documents to determine suitability.

Two-wire smoke detectors only connect to the D7212 through the D125B Powered Loop Interface so that an earth ground will not cause an alarm. Two-wire detectors must be evaluated for electrical compatibility, and must be UL listed for use with the D7212. See the Radionics Technogram *Smoke Detectors Compatible with the D7212* (73-06143-000), or you may contact the detector manufacturer.

Fire Applications (Continued)

Other initiating devices, including four-wire smoke detectors connect to the D7212 through the D129 Dual Class A Initiation Circuit Module, the D125B Powered Loop Interface, or D8127 POPITs. When using 4-wire smoke detectors, install a suitable power supervision unit according to the manufacturer's instructions. Use the D130 Relay Module, D8129 OctoRelay, or terminal 8, Switched Aux Power to provide reset capability. See the *Off-Board Relays* section of this manual for details on installation of the D8129.

For battery calculations, refer to pages 68-69 and the current rating chart on page 66.

Test weekly: Radionics recommends you perform a Fire Test (Command 58) weekly. The AC power is automatically tested as is the battery per UL 864.

Enclosures

Radionics offers three optional enclosures for the D7212M and provides the D6103 for use with the D7212LC.

- The **D8109** is normally used for commercial fire alarm applications. UL lists the D8109 for all commercial fire alarm applications. The D8109 is approved by the California State Fire Marshal, and must be used for NYC-MEA and FM applications.

Note: All references to NFPA and related requirements are based upon compliance with the 1993 edition of NFPA 72, National Fire Alarm Code. Since installation specifications are nearly always based upon a specific edition of a standard which has been legally adopted by the Authority Having Jurisdiction (AHJ), earlier editions of NFPA standards will generally apply. Consult with the appropriate AHJ for confirmation.

System Chart

	Household Burglary	Household Fire	Household Fire / Burglary Combined	Central Station Burglary (Grade C)	Police Connected Burglary	Local Burglary	Remote Station or Auxiliary Fire	Local Fire / Burglary Combined	Local Fire	Local and Central Station Fire Combined	Local and Central Station Fire / Burglary (Grade C)	Central Station Fire / Burglary Combined	Central Station Fire Electrically Actuated Transmitter
Minimum Hours of Standby Battery	4	4 mins	4 mins	4	4	4	60 mins	5 mins	5 mins	5 mins	5 mins	5 mins	5 mins
D6103 / D8103 Encl. D8108A Enclosure	Choose one. D101 lock required for enclosure.			No Req.	No Req.	No	No	Choose one	No	No	No	No	No
D8109 Enclosure				No	No	No	No	Choose one.					
D122 Dual Battery Harness	Calculate current draw to determine if second battery is required.						Req.	Calculate current draw to determine if second battery is required.					
D125B Powered Loop Interface	Opt.	#	#	Opt.	Opt.	Opt.	# - D125 or D129 required to connect fire alarm initiating devices to zones 1 to 8. D125 provides two powered loops for connecting listed 2-wire smoke detectors. D129 provides two non-powered Class A initiating circuits.						
D129 Class A Initiating Module		#	#										
D126 Battery	1+	1+	1+	1+	1+	1+	2+	1+	1+	1+	1+	1+	1+
D127 Reversing Relay	Opt.	No	Opt.	Opt.	Opt.	Opt.	No	Opt.	No	No	Opt.	Opt.	No
D128 Dual Phone Line Module	Opt.	Opt.	Opt.	Opt.	Opt.	Opt.	Required for communication on two phone lines and/or CPU watchdog function.						
D161 Telephone Cord	Required to connect panel to RJ31X TelCo Block.						2 Req.		Two Required to connect D128 Module to RJ31X TelCo Blocks.				
D184 Auxiliary Interface Kit							*						
D192C Bell Circuit Supervision	Opt.	Opt.	Opt.	Opt.	Opt.	Opt.	Required for indicating circuits.					Opt.	Opt.
D262 / D260 Smoke Detector / Base		1•	1•				Opt.	Opt.	Opt.	Opt.	Opt.	Opt.	Opt.
D268 / D269 Independent Zone Control	Optional, only connect to zones 1 to 8.												
D431, D435, D438, D440, D442, D448, Indicating Device	1+	1+	1+	Opt.	♦	♦	1+	1+, ♦	1+	1+	1+	Opt.	Opt.
D461 Pull Station	Optional, may be required by job specification and/or Authority Having Jurisdiction.												
D1255 Command Center	1+	1+	1+	1+	1+	1+	1+	1+	1+	1+	1+	1+	Opt.
D1640 Transformer	Required for all applications.												
D8004 Transformer Enclosure	Opt.	Opt.	Opt.	Opt.	Opt.	Opt.	Required						
D8122 Derived Channel S.T.U.	Optional, contact TelCo for availability of derived channel service.												
D8125 POPEX Module	Required for D8127T/U POPITs.												
D8127T/U POPIT Module	Opt.	Opt.	Opt.	Opt.	Opt.	Opt.	Opt.	Opt.	Opt.	Opt.	Opt.	Opt.	Opt.
D8128A OctoPOPIT	Opt.	No	Opt.	Opt.	Opt.	Opt.	No	Opt.	No	No	Opt.	Opt.	No
D8129 OctoRelay	Optional, for remote annunciation of system functions.												
D8130 Release Module	Optional												
D8132 Battery Charger	See Current Rating Chart and Standby Battery Requirements in D7212 Operation and Installation Manual to determine if system requires a D8132 module for increased battery standby.												
D9131 Printer Interface	Optional, use with parallel printer to print events from panel log locally.												

2+ = Two or more required for this application. Consult the appropriate standard.
 1• = At least one detector required. You can substitute other 2-wire detectors listed for use with the D125. You could also use the D262 with the D270 four-wire base and a listed power supervision relay.
 ♦ = Listed bell (siren) housing required for burglary alarm bell or siren.
 □ (Empty Box) = Not used for this application.
 * = Auxiliary requires the D184 Auxiliary Local Energy Interface Kit.

No = Not acceptable for this application
 Req. = Required for this application
 Opt. = Optional for this application
 # = D125 or D129 required to connect fire alarm initiating devices to zones 1 to 8. D125 provides two powered loops for connecting listed 2-wire smoke detectors. D129 provides two non-powered Class A initiating circuits.
 1+ = One or more required for this application. Consult the appropriate standard.

System Wiring Diagram, Issue A

Current Rating Chart for Standby Battery Calculations

<u>Model Number</u>	<u>Number Used</u>	<u>AC Power On Normal Current</u>		<u>AC Power Off Minimum Current</u>		<u>In Alarm Maximum Current</u>	
		<u>Each Unit</u>	<u>Total</u>	<u>Each Unit</u>	<u>Total</u>	<u>Each Unit</u>	<u>Total</u>
D7212	___	250 x 1 =	<u>250</u>	250 x 1 =	<u>250</u>	500 x 1 =	<u>500</u>
D125B	___	20 X Quan.=	___	19 x Quan.=	___	123 x Quan.=	___
D127	___	13 x Quan.=	___	12 x Quan.=	___	45 x Quan.=	___
D128	___	14 x Quan.=	___	14 x Quan.=	___	45 x Quan.=	___
D129	___	25 x Quan.=	___	25 x Quan.=	___	26 x Quan.=	___
D192C	___	15 x Quan.=	___	26 x Quan.=	___	50 x Quan.=	___
D1255	___	104 x Quan.=	___	106 x Quan.=	___	206 x Quan.=	___
D1256	___	104 x Quan.=	___	106 x Quan.=	___	206 x Quan.=	___
D1257	___	104 x Quan.=	___	106 x Quan.=	___	206 x Quan.=	___
D720	___	55 x Quan.=	___	20 x Quan.=	___	75 x Quan.=	___
D8125	___	48 x Quan.=	___	48 x Quan.=	___	48 x Quan.=	___
D8127	___	3 x Quan.=	___	3 x Quan.=	___	4 x Quan.=	___
D8128A	___	50 x Quan.=	___	50 x Quan.=	___	50 x Quan.=	___
D8129	___	20 x Quan.=	___	20 x Quan.=	___	20 x Quan. + 25 x # relays =	___
D8130	___	5 x Quan.=	___	5 x Quan.=	___	54 x Quan.=	___
D9131	___	24 x Quan.=	___	22 x Quan.=	___	36 x Quan.=	___

Ratings of other devices in the system which are not shown above:

___	___	___ x Quan.=	___	___ x Quan.=	___	___ x Quan.=	___
___	___	___ x Quan.=	___	___ x Quan.=	___	___ x Quan.=	___
___	___	___ x Quan.=	___	___ x Quan.=	___	___ x Quan.=	___
___	___	___ x Quan.=	___	___ x Quan.=	___	___ x Quan.=	___

Total A = ___ **Total B =** ___ **Total C¹ =** ___

Currents shown in milliamperes (1 ampere=1000 milliamperes).

¹ If the column C total exceeds 1900 mA, a D8132 is required to provide an additional 1400 mA. You may also use a UL listed external power supply for this purpose.

Standby Battery Requirements

Household Burglary and Commercial Burglary

Four hours of standby battery capacity required.

Central Station or Local Fire Alarm

24 hours of standby plus 5 minutes of alarm operation required. See *Central Station or Local Systems Ampere-Hour Calculation Formula* in the *Standby Battery Calculation for NFPA 72 Fire Alarm Applications* section.

Remote Station or Auxiliary Fire Alarm

60 hours of standby plus 5 minutes of alarm operation required. See *Remote Station or Auxiliary System Ampere-Hour Calculation Formula* in the *Standby Battery Calculation for NFPA 72 Fire Alarm Applications* section.

Household Fire Warning Equipment

24 hours of standby plus 4 minutes of alarm operation required. See *Household Fire Ampere-Hour Calculation Formula* in the *Standby Battery Calculation for NFPA 72 Fire Alarm Applications* section.

Standby Battery Calculation for NFPA 72 Fire Alarm Applications

Current Chart First

See the *Current Rating Chart for Standby Calculations* for totals B and C used in the formulas below. When connecting two batteries, use either the D122 Dual Battery Wiring Harness or the D8132 Battery Charger Module.

Central Station or Local Systems

Central Station or Local Systems require 24 hours of standby plus 5 minutes of alarm operation at the end of the 24 hour period. A single battery is sometimes adequate for Central Station Systems, but you must install two batteries to meet the basic standby requirements for a Local System installation. You must use battery ampere hour (Ah) calculations to verify compliance. The following formula includes the calculation for 5 minutes of alarm operation at the end of the 24 hour period, as well as a 10% contingency factor which allows for depletion of battery capacity with age.

Central Stations or Local Systems Ampere-Hour Calculation Formula

$$\left(\frac{\text{Total B}}{\text{Hours}} \times 24 \right) + \left(\frac{\text{Total C}}{\text{Hours}} \times .083 \right) + 10\% = \text{Total Ah}$$

Total Ah requirements must not exceed Ah capacity of batteries:

Two D126 Batteries = 14 Ah

Remote Station or Auxiliary Systems

Remote Station or Auxiliary Systems require 60 hours of standby plus 5 minutes of alarm operation at the end of the 60 hour period. A D8132 Battery Charger Module with additional batteries installed in a separate D8109 or D8108A enclosure may be required in the D7212 system to meet the basic standby requirements for a Remote Station or Auxiliary System installation. You must use battery ampere hour (Ah) calculations to verify compliance. The following formula includes the calculation for 5 minutes of alarm operation at the end of the 60 hour period, as well as a 10% contingency factor which allows for depletion of battery capacity with age.

Remote Station or Auxiliary Systems Ampere-Hour Calculation Formula

$$\left(\frac{\text{Total B}}{\text{Hours}} \times 60 \right) + \left(\frac{\text{Total C}}{\text{Hours}} \times .083 \right) + 10\% \text{ Contingency} = \text{Total Ah}$$

Total Ah requirements must not exceed Ah capacity of batteries:

Two D126 Batteries = 14 Ah

Household Fire Warning Equipment

The Household Fire Warning Equipment Standard requires 24 hours of standby plus 4 minutes of alarm operation at the end of the 24 hour period. You must use battery ampere hour (Ah) calculations to verify compliance. The following formula includes the calculation for 4 minutes of alarm operation at the end of the 24 hour period, as well as a 10% contingency factor which allows for depletion of battery capacity with age.

Household Fire Ampere-Hour Calculation Formula

$$\left(\frac{\text{Total B}}{\text{Hours}} \times 24 \right) + \left(\frac{\text{Total C}}{\text{Hours}} \times .067 \right) + 10\% \text{ Contingency} = \text{Total Ah}$$

Total Ah requirements must not exceed Ah capacity of batteries:

Two D126 Batteries = 14 Ah

Troubleshooting Guide

Introduction

Radionics provides this guide to help you troubleshoot problems with the D7212. To prevent problems from occurring, read the preceding sections of this manual and the program entry guide to verify that the panel is correctly installed and programmed.

Self Diagnostics

The D7212 performs a series of self diagnostic tests of its hardware, software, and program at start up and reset.

Buzzer sounding is normal at start-up: The on-board buzzer located on the lower right corner of the panel sounds as the D7212 performs its self diagnostic tests at start up and reset. The tests take approximately ten seconds. If all tests are completed successfully, the buzzer turns off.

The panel continues periodic internal testing during normal operation. If a fault is detected during this testing the buzzer begins sounding . One of the system messages listed below displays at the command centers.

CALL FOR SERVICE - Trouble at Command Center

When a command center stops receiving data from the panel, CALL FOR SERVICE appears in the command center's display. No buzzer sounds at the command center.

PANEL BROKEN - Hardware, Software Failed

If a hardware or software problem causes the buzzer to sound, the green operation monitor LED stops flickering or is off. PANEL BROKEN appears in the displays of all command centers.

Pressing CMD 4 does not silence the buzzer. You must return the panel to Radionics for repair. Attach a Radionics *Return Tag* or call Customer Service for a return authorization.

PARAM FAIL - Program Parameters Failed

If a corrupted program causes the buzzer to sound, the green operation monitor LED continues to flicker. See *Operation Monitor LED* in the *Telephone Connections* section for a description of the green LED. PARAM FAIL alternates with the idle text at the command centers. The panel sends a PARAM FAIL report to the receiver.

Pressing CMD 4 may silence the buzzer.

Silencing the buzzer does not correct the problem: You must replace the corrupted copy of the program in the panel. Load a new copy of the complete program.

The displays clears when you reset the panel after loading a new program.

SERV AC FAIL - AC Power Failed

An interruption of AC Power at terminals 1 and 2 causes SERV AC FAIL to appear in command center displays. You can program the panel to send an AC FAILED report to the receiver. Pressing CMD 4 silences the buzzer. Restoring power clears the display.

SERV BATT LOW - Battery Voltage Low

If battery voltage at terminals 4 and 5 falls below 12.1 VDC, a SERV BATT LOW appears in command center displays. See *Battery and Power Reports* in this section for probable causes and remedies.

Pressing CMD 4 silences the buzzer. The display clears when battery voltage reaches 13.7 VDC.

SERV BATT MSING - Battery Missing, Shorted, or Reversed

If the panel can not detect a battery at terminals 4 and 5, a SERV BATT MSING appears in command center displays. You can program the panel to send a BATTERY MISSING report to the receiver.

Pressing CMD 4 silences the buzzer. Restoring the battery clears the display.

SERV COMM FAIL - Communications Failure

SERV COMM FAIL appears in command center displays after the panel makes 10 unsuccessful attempts to report to the receiver.

Pressing CMD 4 silences the buzzer. The display clears when communication restores (the receiver acknowledges a report). See *Communication Failure* in the *Telephone Connections* section for a complete description.

SERV KEYPAD - Supervised Command Center Missing

When the panel loses contact with a supervised command center, SERV KEY PAD appears at other command centers connected to the panel. The panel transmits an SDI FAILURE report to the receiver.

Pressing CMD 4 silences the buzzer. The displays clear when contact with the missing command center restores.

SERV PH LINE #1 (or 2) - Phone Line Failure

SERV PH LINE #1 (SERV PH LINE #2) appears in command center displays when the panel detects a phone line as faulted.

Pressing CMD 4 silences the buzzer. The display clears when the panel detects a normal phone line. See *Phone Line Monitor* in the *Telephone Connections* section for a complete description.

SERV PRINTER - Supervised Printer Missing

When the panel loses contact with a supervised printer, SERV PRINTER appears in command center displays.

Pressing CMD 4 silences the buzzer. The displays clear when contact with the missing printer restores.

Phone Line Trouble

Phone line problems that are not corrected can result in the D7212 going into Communications Failure. You can program the D7212 to monitor one or two phone lines. See the *D7212 Program Entry Guide* (74-06915-000) for programming instructions.

If you enable the phone line monitor, SERVC PHONE LINE #1 (or 2 if two lines are used) appears in the command center's display when the D7212 detects a problem on the phone line.

Symptom	Diagnosis	Remedy
<p>SERV PH LINE #1 (or 2 if two lines are used) appears in command center display.</p>	<p>D7212's phone line monitor detects a phone line as faulted.</p>	<ol style="list-style-type: none"> 1. Verify that the telephone cord is correctly connected to the RJ31X and the D7212. 2. Verify the Ground Start Jumper is in the correct position. 3. If using a ground start phone line, verify D136 relay is in socket K6/J5. 4. Verify that the RJ31X jack is wired correctly. The incoming phone line must be wired to terminals 4 and 5. The in-house phone system must be wired to terminals 1 and 8. 5. Verify that all telephones are on-hook. Leaving a telephone on hold after the other party hangs up creates an off-hook condition. Verify that no phones are on hold. <p>If completing the steps above does not restore the phone line, meter the phone lines. You should meter at least 7.5 VDC when the line is idle (on-hook). You should meter at least 13 mA of current when the line is active (off-hook). If your readings are below the minimum values, contact your telephone company repair service.</p>

Communications Failure

The D7212 goes into Communications Failure after ten unsuccessful attempts to reach the receiver. Follow the *Phone Line Trouble* procedure to verify that there is no problem with the phone lines at the D7212 installation. If the phone lines are good, monitor the lines (preferably at the receiver) for the symptoms listed below.

Symptom	Diagnosis	Remedy
The line rings but the D6500 receiver does not pick up. RING indicator on line card does not light. Can not hear ring with headset at receiver location.	Line is not ringing at the receiver.	<ol style="list-style-type: none"> Verify that the lines are correctly connected to the receiver. Verify that correct prefixes and phone numbers for the receiver have been programmed into the D7212. <p>If completing the steps above does not correct the problem, contact your telephone company repair service.</p>
The line rings but the receiver does not pick up. RING indicator on line card lights. Can hear ring with test set at receiver location.	Line card in receiver may be faulty.	Review receiver manuals for trouble shooting procedures.
The D7212 reaches a busy signal for all ten attempts to reach the receiver.	Calls are not reaching the receiver.	<ol style="list-style-type: none"> Verify that correct prefixes and phone numbers for the receiver have been programmed into the D7212. Verify that the phone lines are not shorted between the phone company's equipment and the receiver by placing a call to the number for the receiver. If you hear the line ring, but the ring detector doesn't light, or if you hear a busy signal and the green on line (OL) indicator is not lit, call the phone company for service.
	The receiver's call load is too great.	Additional line cards and phone lines may be needed for the receiver.
The receiver answers the call and provides an acknowledgment tone, but the communicator does not transmit reports.	The receiver is not producing the correct acknowledgement tone.	Verify that the receiver is producing a 1400 Hz, 2300 Hz, or Modem II acknowledgment tone.
	The D136 relay in J10 for ground start phone systems is inserted incorrectly.	Insert the D136 relay in socket J10 correctly. See the <i>Relays</i> section of this manual for instructions.

Communications Failure (Continued)

Symptom	Diagnosis	Remedy
The receiver answers the call and provides an initial "handshake" acknowledgment, but does not acknowledge the D7212's report transmission with a "kiss-off" acknowledgment .	The receiver is not compatible with the D7212's transmission format.	Verify that the receiver is compatible with the format the D7212 is using (either BFSK or Modem II). See <i>Phone</i> in the <i>D7212 Program Entry Guide</i> (74-06915-000). Modem II requires D6500 MPU and Line Card EPROM revision 6.00 or higher.
	Noisy phone lines are interfering with report transmission.	Try making a voice call to the receiver on the line to verify the noisy condition. It may be necessary to have the phone company check the lines.

Problems Programming the Panel

Before attempting to program the D7212, you should be familiar with the basic operation of the D5200 programmer. See the *D5200 Operation Manual* (74-06176-000). If you still experience problems, check for the symptoms below.

Symptom	Diagnosis	Remedy
The programmer displays PLUG IN 7212 when you press SEND or RECV.	The programmer is not correctly connected to the D7212.	<ol style="list-style-type: none"> 1. Verify that the data/power cord is plugged into the COMMUNICATOR port on the D5200. 2. Verify that the data/power cord is plugged securely into the D5200 programmer. 3. Check each conductor in the data/power cord for continuity.
	AC induction through the on-board point sensor loops, the DATA BUS, or the ZONEX BUS.	<ol style="list-style-type: none"> 1. Verify a proper earth ground at terminal 10. 2. Disconnect on-board point sensor loops, the DATA BUS (terminals 30, 31), and the ZONEX BUS (terminals 27,28).
After plugging in the programmer, the panel transmits SDI trouble reports for supervised SDI devices (command centers, printer interface modules, etc.). All SDI devices stop operating.	You haven't entered the D7212 handler within 30 seconds of plugging in the programmer.	<p>Enter the D7212 handler within 30 seconds of plugging in the programmer.</p> <p>Once the SDI reports are generated, entering the handler or disconnecting the programmer returns the SDI devices to normal operation.</p>

Problems with Points

Symptom	Diagnosis	Remedy
Point appears as missing at command centers and in reports to the receiver.	POPIT is not connected or incorrectly connected to the data expansion loop.	Disconnect the EOL resistor from the loop output of the POPIT. You should measure 8 to 13 VDC, constant.
	Sensor loop switch (1 to 8) is turned off on OctoPOPIT.	If the sensor loop switch on an OctoPOPIT is turned off for a programmed point, the point reports as missing.
	Switch 12 ON for more than one OctoPOPIT connected to ZONEX. Switch 12 ON for OctoPOPIT connected to same ZONEX as a D8125.	Connect only one OctoPOPIT with switch 12 ON to ZONEX. If ZONEX is connected to a D8125, turn switch 12 OFF for all OctoPOPITs connected to that terminal.
	POPIT is not programmed correctly.	Verify that the switches on the POPIT are set for the missing POPIT number. Switches set incorrectly can cause both missing and extra POPITs.
Points intermittently appear as missing. Points are erratic.	Problem with data expansion loop.	See <i>Problems with Data Expansion Loop</i> .
	Debounce Count parameter set at 1. If an off-board point is in transition between normal and faulted conditions as the panel scans it, it appears as missing.	Radionics recommends that the Debounce Count be left at the default of 2. Decreasing the Debounce Count to 1 may cause points to appear as missing. Increasing the Debounce may cause missed alarms.

Problems with Points (Continued)

Symptom	Diagnosis	Remedy
One or more points remain in trouble or alarm with all devices connected to the sensor loops normal.	<p>The sensor loop is open, shorted, or grounded.</p> <p>Opens, shorts, or grounds cause troubles or alarms depending on point programming.</p>	<p>Remove the sensor loop from the D7212 or POPIT and meter it for continuity. There should be no more than 100Ω resistance, plus the value of the end of line resistor on the wires. If you meter less resistance than the value of the end of line resistor, check the wiring for shorts.</p> <p>With the wires for the loop removed, meter them for continuity to ground. A ground before the end of line resistor on an on-board point's sensor loop is interpreted as a short. A ground on a sensor loop for a POPIT point is interpreted as an open.</p>
Faulted points do not generate alarms or troubles as programmed.	Command 47 pressed at the time the alarm or trouble was generated.	The D7212 ignores input from all points in the same area programmed for sensor reset during sensor reset (Command 47).
	Two points are programmed with the same address.	Points programmed with the same address do not function correctly. Check to be certain that you have not duplicated point addresses.
Panel transmits PT BUS TROUBLE reports. Erroneous alarm and/or trouble reports may follow PT BUS TROUBLE report. Erroneous alarm and/or trouble events for off-board points appear at command centers.	Short on D8125 POPEX module's Data Expansion Loop or short on D7212's ZONEX data terminals (27 & 28).	<p>A short on the Data Expansion Loop or the ZONEX data terminals generates a PT BUS TROUBLE report.</p> <p>While the short remains, the panel responds as though the sensor loop for each point connected to the POPEX module was shorted.</p> <p>Check wiring for shorts.</p>
	A POPIT has its switches set incorrectly and it's sensor loop is shorted.	Check to be certain all POPIT switches are set correctly.

Problems with Points (Continued)

Symptom	Diagnosis	Remedy
All off-board points are MISSING.	Short on Aux Power, terminal 3.	Terminal 3 shares a common circuit breaker. Check wiring and devices connected to this terminal for shorts or grounds.

Problems with the D8125 POPEX Data Expansion Loops

EMI (Electro-magnetic Interference), excessive resistance, or intermittent grounds, shorts, or opens on the data expansion loop can cause erratic or intermittent functioning of points. Follow the procedures below to find the source of problems on the data expansion loop.

EMI

If you suspect EMI may be a problem, see *EMI on Long Wire Runs* in this section. AC induction on the data expansion loops must be less than 10 VAC.

Metering the Loops

Before you follow the procedures below to meter the data expansion loops, check Table 1 to be sure you used the correct gauge wire for the length of the data expansion loops.

When you meter the loop, monitor it long enough to observe an intermittent problem.

To meter the data expansion loop without POPITs connected to it:

1. Disconnect the loop from the POPEX module.
2. Twist the positive and then the negative wires together at each POPIT location so that the positive and negative wires are continuous to the last POPIT location.
3. At the last POPIT location twist the end of the positive wire to the negative wire to form one continuous loop.
4. Meter the loop for continuity from the point where it connected to the POPEX module. Resistance for the entire loop must be less than 60Ω . If there is no continuity, find and repair the open on the loop.
5. Still metering for continuity, untwist the negative and positive wires at the last POPIT location. If the meter does not show an open condition, find and repair the short on the loop.
6. Twist the positive and negative wires at the last POPIT location back together.
7. Meter the loop for continuity to terminal 10 (earth ground). If there is continuity, find and remove the foreign ground on the loop.
8. Meter the loop to terminal 10 for AC voltage. AC induction on data expansion loops must be less than 10 VAC. Try using shielded cable to reduce AC induction if the AC voltage exceeds 10 VAC.

Checking Shielded Cable

If improperly installed, shielded cable can create problems rather than solve them. Follow the procedure below to check shielded cable for proper installation.

1. Remove the drain wire for the shield from terminal 10.
2. Meter the drain wire for continuity to terminal 10 (earth ground). If there is continuity, find and remove the foreign ground on the drain wire.
3. Reconnect the drain wire to terminal 10.
4. Meter the shield at the far end of the cable (last POPIT location on data expansion loops) for continuity to a ground reference. If there is no continuity, find and repair the open in the shield. Solder and tape all connections.

EMI on Long Wire Runs

EMI (ElectroMagnetic Interference) can cause problems on long wire runs for serial devices (command centers, POPITs, etc.). The use of shielded cable reduces the effect of this interference. Some potential sources of noise on a long wire run include:

- Radio or television transmitter site.
- Ham radio operator's transmitter site.
- Computer network system.
- Heavy machinery (large electrical motors).
- PBX telephone system.
- High voltage electrical equipment or transformers (arc welders, certain medical and dental equipment, etc.).
- Public service office using radio communications (fire department, police department, etc.).
- Close proximity to electrical lines, telephone cabling, or fluorescent lighting fixtures.

There are many other possible sources of noise. If you suspect that noise may be a problem, the use of shielded wire is strongly recommended. Connect the drain wire from the shielded cable to terminal 10 on the D7212.

The drain wire must have continuity from the panel to the last serial device on the wire run. If you cut the cable to install devices between the last device and the panel, be certain to reconnect the drain wire to insure continuity to the last serial device.

If continuity is not maintained between the panel and the last serial device, the shielded cable may aggravate potential noise problems rather than eliminate them. Connecting the drain wire to ground at other than terminal 10 on the panel may also produce problems. Do not connect the drain wire to any other ground source.

Problems with Command Centers

Symptom	Diagnosis	Remedy
<p>Command centers show erratic behavior.</p> <p>For example, the pip that confirms you pressed a key "echoes" or the back lighting flashes off and on.</p>	<p>A supervised address has been entered in more than one command center.</p>	<p>Entering a supervised address in more than one command center causes erratic behavior.</p> <p>Use a supervised address in one command center only.</p>
	<p>One or more of the keys is stuck under the faceplate</p>	<p>Press each of the keys on the command center to be certain none of them is stuck.</p>
	<p>Data connections (yellow and green wires) on one or more command centers are reversed, or only one wire is connected.</p>	<p>Check to be sure that the yellow and green data wires are correctly connected at all command centers.</p>
<p>NO AUTHORITY displays at command center when you enter your passcode to perform a function.</p>	<p>Check the <i>User Interface</i> section of the program to be sure the function is enabled for Authority Level assigned to the passcode in the <i>Passcode Work sheet</i> section of the program.</p> <p>Check the <i>Passcode Worksheet</i> section of the program to be certain the passcode is assigned to the area where you are attempting to perform the function.</p> <p>Check the <i>Passcode Worksheet</i> section of the program to see if the passcode is restricted by a user window.</p> <p>Check the <i>Area Parameters</i> section of the program to be certain the area you are attempting to perform the function in is turned on.</p>	

Battery and Power Reports

You can program the D7212 to transmit both battery and AC power status reports. See the *D7212 Program Entry Guide (74-06915-000)*. If battery or AC power reports are a problem check the following.

1. Check to be sure you are not overloading the D7212's power supply. Review the *Power Outputs* section and *Overloaded Power Supply* in this section.
2. Verify that there is at least 16.5 VAC on terminals 1 and 2.
3. The outlet the transformer is plugged into should meter between 110 VAC and 120 VAC.
4. Verify that the output for the transformer connected to terminals 1 and 2 is rated for 16.5 VAC and at least 40 VA.
5. Disconnect the transformer from terminals 1 and 2 and meter the battery at terminals 3 and 4. A fully charged battery should show 13.8 volts.
6. Make sure the battery is a 12 V sealed lead acid type. It should be rated at 7 Ah or greater, depending on the NFPA classification of the installation.

Watchdog Reset Reports

The D7212 sends a WATCHDOG RESET report whenever the panel's CPU (Central Processing Unit) is interrupted and has to start its normal operating sequence over. The on-board buzzer sounds briefly during the WATCHDOG reset. The panel returns to normal operation immediately after resetting.

The most common cause of CPU interruption and WATCHDOG RESET reports is static discharge to the panel. Static discharges may also corrupt the panel's program. The D7212 displays a PARAM FAIL message at the command centers and sends PARM CKSUM FAIL report if the program is corrupted.

Shorting terminals 3, 6, 7, or 8 to ground may also cause a WATCHDOG RESET. Remove the short to continue normal operation.

A single isolated WATCHDOG RESET report does not mean you have to replace the panel. If you experience frequent reports, contact Radionics Customer Service for help.

Touch Terminal 10 first: If the on-board buzzer sounds briefly when you first touch the panel, you're discharging any static charge you may be carrying to the panel. The panel may generate WATCHDOG RESET and/or PARAM FAIL events. Always touch terminal 10, the panel's earth ground connection, before beginning work on the panel.

Runaway Reports to the Receiver

Using the D8128 in place of the D8128A OctoPOPIT Module may cause runaway reports to the receiver on AC failure. If you installed the D8128 be sure to replace it with the D8128A module.

Overloaded Power Supply

If the load on the D7212's power supply exceeds its capacity, the panel follows a routine to protect itself and the battery. It sends reports to the receiver at several points during this routine.

Keep in mind that AC power remains at terminals 1 and 2 as you read the overload scenario below.

- The panel is operating normally with a good battery, AC is present at terminals 1 and 2, and auxiliary power load is under 1.4A.
- Combined load on terminals 3, 6, 7, 8, and connector J2 exceeds and remains above 1.4A. Device failure or premises wiring ground faults might cause the increased load.
- The panel begins drawing on the battery to support the increased load. The yellow charging status LED turns on.
- The battery begins to drain. When voltage drops to 12.1 volts, the panel sends a LOW BATTERY report and turns on the red Low Battery LED.
- When the battery drops to 10.2 volts the panel disconnects it to protect it from deep discharge.
- If AC is still present, the panel removes power to terminals 3, 6, 7, 8, and 32 to protect its power supply. The green operation monitor LED turns off, but the panel is still operating.
- The panel sends BATTERY MISSING, PT BUS TROUBLE, and SDI FAILURE reports.
- If a D128 module is connected to J2, it begins sounding.
- After approximately 60 seconds the panel attempts to return to normal operation by returning power to terminals 3, 6, 7, 8, and 32.
- If the overload condition is still present, the panel removes power.
- The panel attempts to return to normal operation approximately every 60 seconds.
- The cause of the overload is removed. Combined load on terminals 3, 6, 7, 8, and 32, and connector J2 remains below 1.4A.
- With the overload removed, the panel returns power to terminals 3, 6, 7, 8, and 32. The panel sends PT BUS RESTORAL and SDI RESTORAL reports.
- If a D128 module is connected to J2, it stops sounding.
- If the battery voltage is below 8.4 volts, the panel does not reconnect it. You must replace the battery.
- When the battery reaches 13.7 volts the panel sends a BATTERY RESTORE report and turns off the red Low Battery LED.
- When the battery reaches 13.9 volts the panel turns off the yellow Charging Status LED.

Command 5 7 Toggles Default Idle Text

Command 5 7 allows technicians who might not be familiar with the custom idle text to confirm whether an area is armed or ready to arm. The default idle text displays are:

AREA # IS ON AREA # IS OFF

Follow the procedure below to toggle between custom and default idle text.

1. Ensure the command center is at idle text.
2. Press **COMMAND 5 7**.
3. The display will change to default idle text for 5 seconds and then revert to its original idle text.

Command 5 9 Shows Firmware Revision

Command 5 9 displays the revision of firmware currently installed in the panel.

1. Ensure the command center is at idle text.
2. Press **COMMAND 5 9**.
3. The current revision of firmware displays (**7212 REV ## - ##**) for 5 seconds.
4. The display returns to idle text.

Specifications

Voltage Input

Primary Power Supply

① ②

16.5 VAC 40 VA class 2 plug-in transformer (D1640)

Secondary Power Supply

④ ⑤

12 VDC 7 Ah sealed lead acid rechargeable battery. The D7212 supports a maximum of two 12 VDC 7 Ah batteries using the D122 Dual Battery Harness.

Current Requirements

Panel - 500 mA

See the *D7212 Standby Battery and Current Rating Chart* for the current requirements of other system components.

Power Outputs

Continuous Power Outputs

③ ③2

1.4A maximum at 10.2 VDC to 13.9 VDC (continuous supply) total for all devices and outputs supplied at terminals 3 and 32, and connector J2.

Alarm Power Output

⑥ ⑦

2.0 A maximum at 10.2 VDC to 13.9 VDC output. Output may be steady or one of three pulsed patterns depending on programming. See the *Relays* section of the *D7212 Program Entry Guide* (74-06915-000)

Switched Aux Power

⑧

1.4 A maximum at 10.2 VDC to 13.9 VDC output. Continuous output is interrupted by Sensor Reset (CMD 47) or alarm verification depending on programming. See the *Relays* section of the *D7212 Program Entry Guide* (74-06915-000)

Fire and Fire/Burglary Systems

To comply with UL 985 and 864 listing standards for fire alarm systems (effective March 1, 1989), the total combined continuous and alarm current draw for the system **during alarm conditions** must be limited to 1.4A (1400 mA) provided by the primary power supply (rectified AC). If current draw for the system exceeds 1.4A, connect a D8132 Battery Charger Module to the D7212. The D8132 provides an additional 1.2 Amps of rectified AC power. Combined current draw must never exceed 2.0A.

Battery Discharge/Recharge Schedule

Discharge Cycle

13.9 VDC	Charging float level
13.8 VDC	Charging Status LED on
12.1 VDC	Low Battery & AC fail reports if programmed, Low Battery LED on
10.2 VDC	Battery load shed (processing functions continue if AC is present)

Recharge Cycle

AC ON	Load shed relay resets battery charging begins, battery trouble and AC restoral reports sent.
13.7 VDC	Battery restoral report sent, Low Battery LED off
13.9 VDC	Charging Status LED off, battery float charged

Minimum Operating Voltage

10.2 VDC

SDI Bus

SDI Bus A (+): 9 VDC (15,000' max)

SDI Bus B (-): 9 VDC (15,000' max)

Telephone Connections

Connection

RJ31X or RJ38X jack can be interfaced with the D7212.

Two TelCo Lines

Radionics D128 Dual Phone Line Module required for two phone line service. Supervision supplied by the panel.

Environmental

Temperature: 32°-122°F (0°-50°C)

Relative Humidity: 5-85% at 86°F (30°C)
non-condensing

Arming Stations

D1255 Command Center

Keypad

Point Thresholds

On-Board Points 1 to 8

	Voltage	Resistance
Normal	2.3	1k Ω
Short	1.85	0.657 Ω
Open	2.93	1.6k Ω

Compatible Enclosures

D8103 Universal Enclosure

D8109 Fire Enclosure

D8108A Attack Resistant Enclosure

D6103 Enclosure with Lock

Compatible Accessories

See the Radionics Product Catalog for complete list.

D122 Dual Battery Harness

D125B Powered Loop Interface Module

D126 12V, 7 Ah Rechargeable Battery

D127 Reversing Relay

D128 Dual Phone Line Switcher

D129 Dual Class A Initiation Circuit Module

D130 Relay Module

D136 Plug-in Relay

D161 Phone Cord

D162 Phone Cord

D192A Bell Circuit Supervision Module

D268/

D269 Independent Zone Control
(on-board and OctoPOPIT points)

D279 Independent Zone Control
(on-board and OctoPOPIT points)

D440 (6"), D442 (10") Bells

D431, D435, D448 12 VDC Horns

D1255 Alphanumeric Command Center

D1256 Fire Command Center

D1257 Fire Annunciator

D720 LED Command Center

D1640 16.5 VAC 40 VA Transformer

D5200 Programmer

D5300 Remote Account Manager II

D8004 Transformer Enclosure

D8121A/

D8122 Derived Channel S.T.U.

D8125 POPEX Module

D8127 POPIT Module

D8128A OctoPOPIT Module

D8129 OctoRelay Module

D8130 Release Module

D8132 Battery Charger Module

D8620A Briefcase Demonstration Kit

D9131 Printer Interface